

◆ Dwg. No. BATS-0961

SIZE	d	L	D	T	BOLT HOLE			H	W	A	F	Q, TY
					C	n	h					
50	50	260	155	16	120	4	19	138	320	96	5.1	
65	65	300	175	18	140	4	19	146	320	99	5.1	
80	80	320	185	18	150	8	19	157	400	117	5.1	
100	100	370	210	18	175	8	19	170	400	132	5.1	

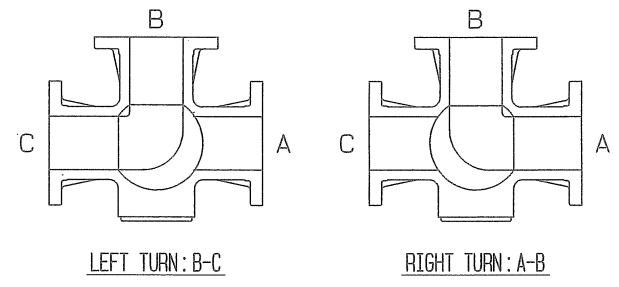
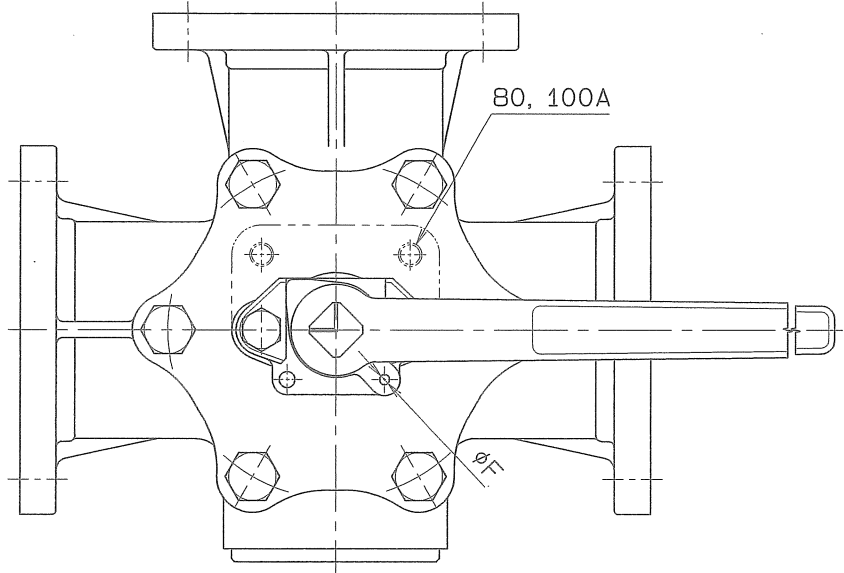

SPEC.		TEST PRESS.	
FLUID		SHELL	HYDRO 2.1 MPa (21.4 kgf/cm ²)
PRESS.	MPa (kgf/cm ²)	SEAT	AIR 0.6 MPa (6.1 kgf/cm ²)
TEMP.	°C	AIR	MPa (kgf/cm ²)

END FLANGED: JIS B 2220

No.	NAME OF PARTS	Q. TY	MATERIALS	REMARKS
20	GLAND BOLT	2	SUS 304	
19	COVER BOLT	6	SUS 304	50A-Q, TY 4
18	HANDLE	1	FCD 450	
17	STOP RING	1	SUS 304	
16	STOPPER	1	SUS 304	
15	BEARING	1	P.T.F.E.	+SUS 316
14	BEARING	1	P.T.F.E.	+SUS 316
13	"O" RING	3	VITON	
12	GASKET PACKING	1	P.T.F.E.	
11	COVER PACKING	1	P.T.F.E.	
10	GLAND PACKING	1SET	P.T.F.E.	
9	BALL SEAT	4	P.T.F.E.	
8	GLAND SLEEVE	1	SUS 316	
7	GLAND	1	SCS 13	
6	SEAT HOLDER (C)	1	SUS 316	
5	SEAT HOLDER (B)	3	SUS 316	
4	SEAT HOLDER (A)	3	SUS 316	
3	BALL DISC	1	SCS 14A	
2	BODY COVER	1	SCS 14A	
1	BODY	1	SCS 14A	

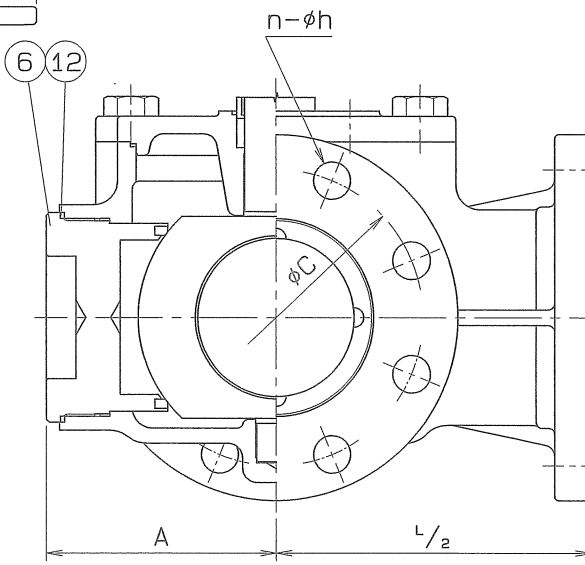
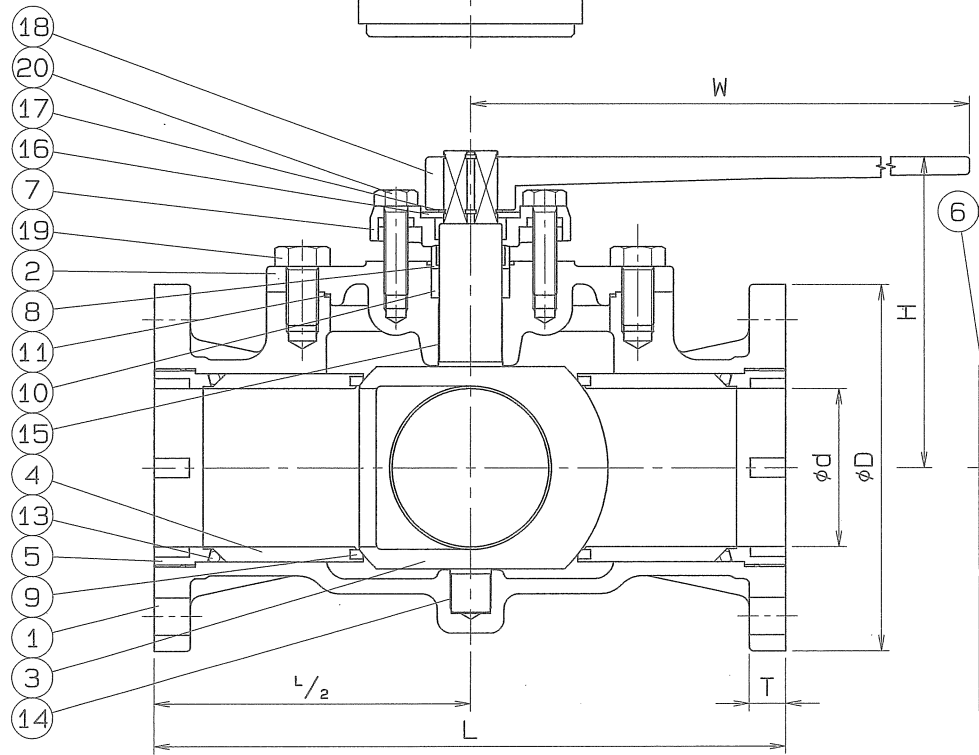

NAME	JIS 10K F.F. FLANGED ENDS 4-SEATS THREE WAY BALL VALVES L-PORT		
TYPE	N-737L	SIZE	50 ~ 100 A
Dwg. No.	BATS-0961	APPROVED BY	<i>H. Yamashita</i>
DATE	APR. 20. 2007	CHECKED BY	<i>H. Takahashi</i>
SCALE		DESIGNED BY	
THIRD ANGLE PROJECTION METHOD		DRAWN BY	<i>H. Takahashi</i>

O. N. INDUSTRIES LTD.