

◇ DMG.No. BAJT-0162

SIZE	FLANGE SIZE	d	L	D	T	BOLT HOLE			H	W	A	B	E	F	Q, TY
						C	n	h							
50	80	50	260	185	18	150	8	19	138	320	95	60	Rp 1/2	5.1	
65	100	65	300	210	18	175	8	19	146	320	98	75	Rp 3/4	5.1	
80	100	80	320	210	18	175	8	19	157	400	116	85	Rp 3/4	5.1	
100	150	100	450	280	22	240	8	23	221	400	131	100	Rp 3/4	5.1	

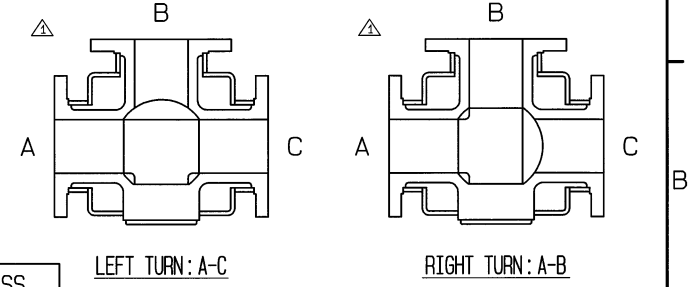
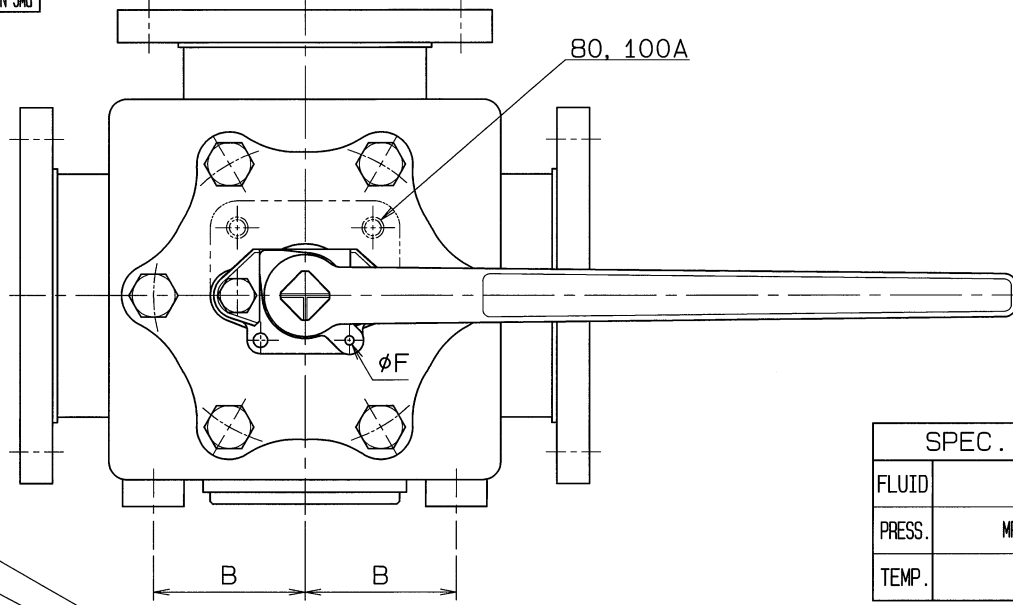

SPEC.		TEST PRESS.	
FLUID		SHELL	HYDRO 2.1 MPa
PRESS.	MPa	SEAT	AIR 0.6 MPa
TEMP.	°C	JACKET	AIR 0.6 MPa

END FLANGED: JIS B 2220

No.	NAME OF PARTS	Q.TY	MATERIALS	REMARKS
24	JACKET		SS 400	
23	SOCKET	3	SS 400	
22	DRAIN PLUG	1	FCMB 27-05	
21	GLAND BOLT	2	SUS 304	
20	COVER BOLT	6	SUS 304	50A Q, TY-4
19	HANDLE	1	FCD 450	
18	STOP RING	1	SUS 304	
17	STOPPER	1	SUS 304	
16	BEARING	1	P.T.F.E.	+SUS 316
15	BEARING	1	P.T.F.E.	+SUS 316
14	O-RING	3	VITON	
13	GASKET PACKING	1	P.T.F.E.	
12	COVER PACKING	1	P.T.F.E.	
11	GLAND PACKING	1SET	P.T.F.E.	
10	BALL SEAT	4	P.T.F.E.	
8	GLAND SLEEVE	1	SUS 316	
7	GLAND	1	SCS 13	
6	SEAT HOLDER (C)	1	SUS 316	
5	SEAT HOLDER (B)	3	SUS 316	
4	SEAT HOLDER (A)	3	SUS 316	
3	BALL DISC	1	SCS 14A	
2	BODY COVER	1	SCS 14A	
1	BODY	1	SCS 14A	

- 19
- 18
- 17
- 21
- 7
- 8
- 20
- 2
- 11
- 12
- 16
- 10
- 4
- 14
- 5
- 1
- 3
- 15
- 24
- 23
- 22

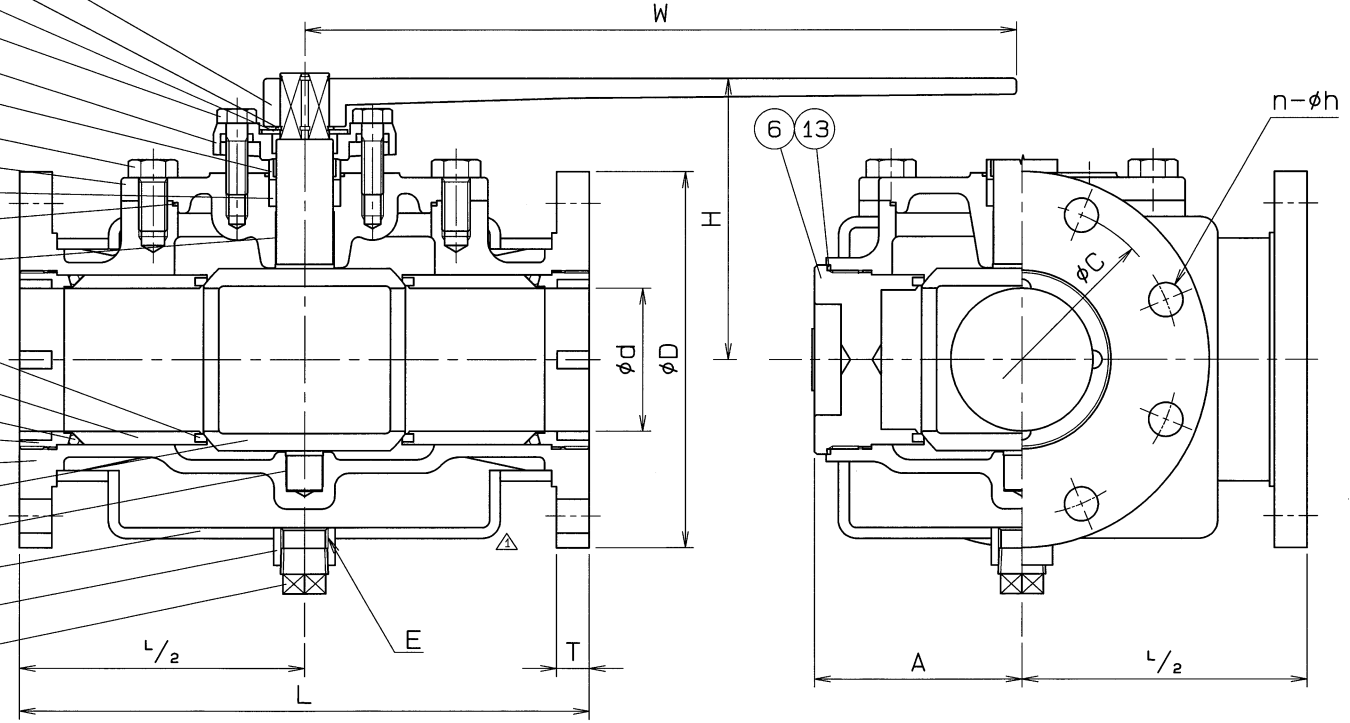

△ ドレナプラグ材質名変更、ボデー形状修正、蓋図変更 '16. 6. 24.

NAME: JIS 10K F.F. FLANGED ENDS 4-SEATS JACKET TYPE THREE WAY BALL VALVES T-PORT

TYPE: N-7037T SIZE: 50 ~ 100 A

DMG.No. BAJT-0162 APPROVED BY: *Sh. Asakura*

DATE: JUL. 23. 2007 CHECKED BY: *Sh. Asakura*

SCALE: DESIGNED BY: *R. Matsuda*

THIRD ANGLE PROJECTION METHOD DRAWN BY: *S. Ogiya*

O. N. INDUSTRIES LTD.