

◇ 964-0964 BATS-0964 DWG.No.

SIZE	d	L	D	T	BOLT HOLE			H	W	A	F	Q, TY
					C	n	h					
50	50	260	155	16	120	4	19	138	320	96	5.1	
65	65	300	175	18	140	4	19	146	320	99	5.1	
80	80	320	185	18	150	8	19	157	400	117	5.1	
100	100	370	210	18	175	8	19	170	400	132	5.1	

A
B
C
D
E
F

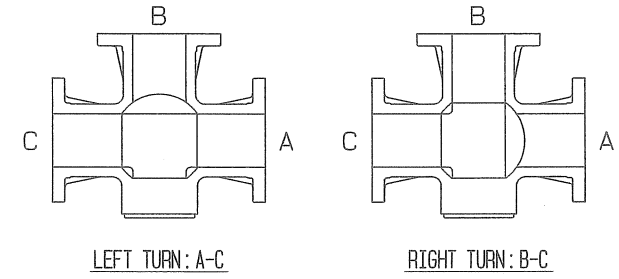
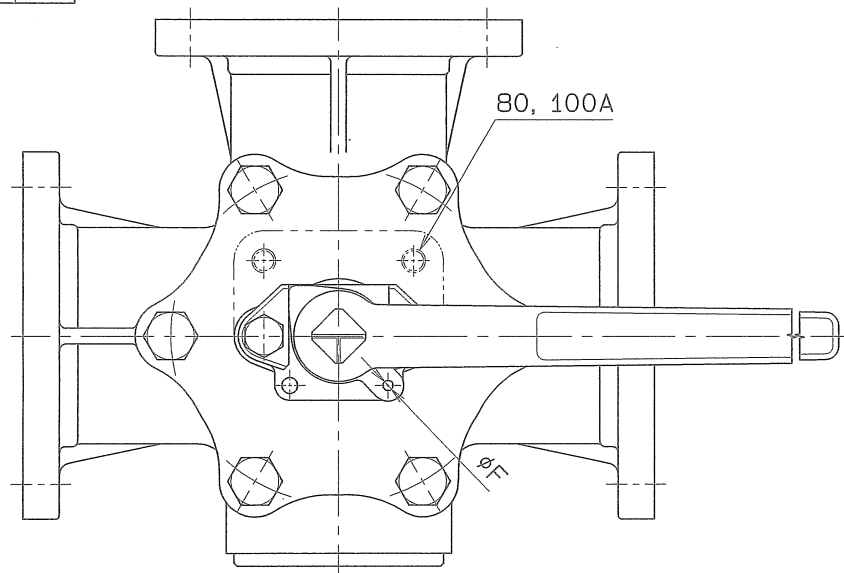

SPEC.		TEST PRESS.	
FLUID		SHELL	2.1 MPa (21.4kgf/cm ²)
PRESS.	MPa (kgf/cm ²)	SEAT	0.6 MPa (6.1 kgf/cm ²)
TEMP.	°C	AIR	MPa (kgf/cm ²)

END FLANGED: JIS B 2220

No.	NAME OF PARTS	Q. TY	MATERIALS	REMARKS
20	GLAND BOLT	2	SUS 304	
19	COVER BOLT	6	SUS 304	50A-Q, TY 4
18	HANDLE	1	FCD 450	
17	STOP RING	1	SUS 304	
16	STOPPER	1	SUS 304	
15	BEARING	1	P.T.F.E.	+SUS 316
14	BEARING	1	P.T.F.E.	+SUS 316
13	"O" RING	3	VITON	
12	GASKET PACKING	1	P.T.F.E.	
11	COVER PACKING	1	P.T.F.E.	
10	GLAND PACKING	1SET	P.T.F.E.	
9	BALL SEAT	4	P.T.F.E.	
8	GLAND SLEEVE	1	SUS 316	
7	GLAND	1	SCS 13	
6	SEAT HOLDER (C)	1	SUS 304	
5	SEAT HOLDER (B)	3	SUS 304	
4	SEAT HOLDER (A)	3	SUS 304	
3	BALL DISC	1	SCS 13A	
2	BODY COVER	1	SCS 13A	
1	BODY	1	SCS 13A	

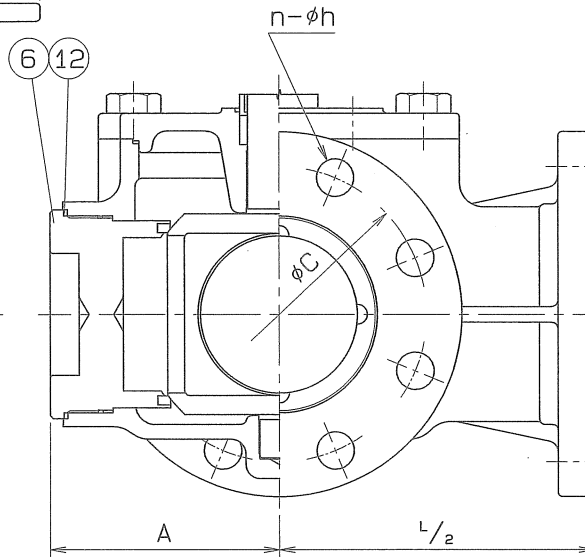
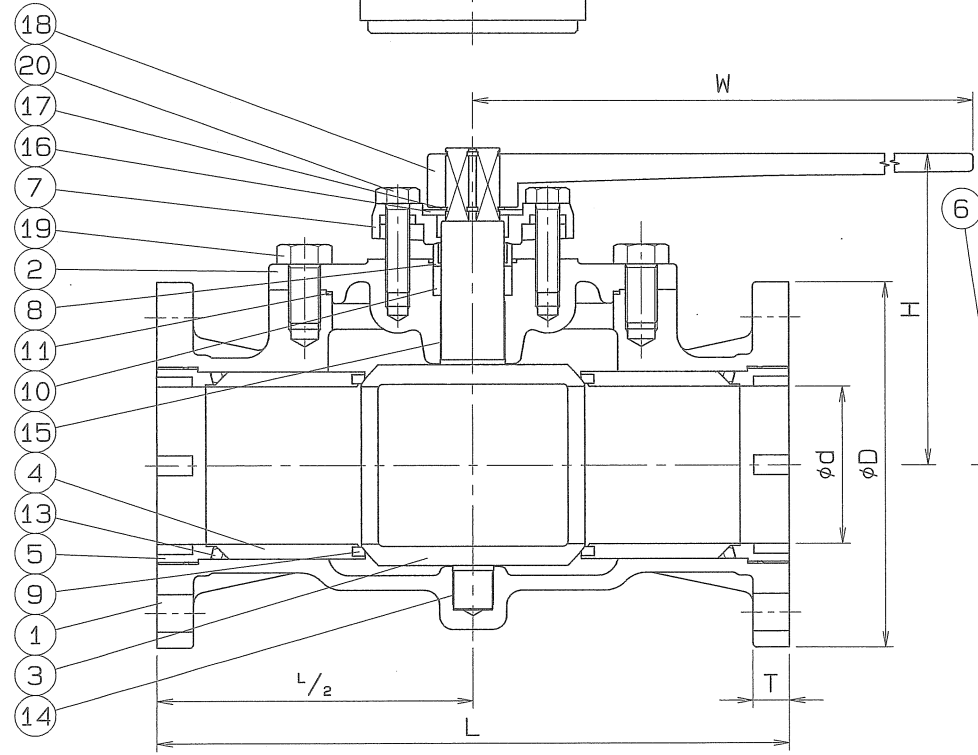

NAME	JIS 10K F.F. FLANGED ENDS 4-SEATS THREE WAY BALL VALVES T-PORT		
TYPE	N-737T	SIZE	50 ~ 100 A
DWG.No.	BATS-0964 ◇	APPROVED BY	<i>K. Furuta</i>
DATE	APR. 20. 2007	CHECKED BY	<i>A. Kishida</i>
SCALE	:	DESIGNED BY	<i>K. Takahashi</i>
THIRD ANGLE PROJECTION METHOD		DRAWN BY <i>K. Takahashi</i>	

O. N. INDUSTRIES LTD.