

DWG. No. BATS-0901

SIZE	P	L	PIPE THREADS	A	H	W	C	E	G	Q, TY
			d							
1	20	100	Rc 1	49.5	105	150	77.5	27	11	
1-1/4	25	115	Rc 1-1/4	57	109	150	81	33.5	11	
1-1/2	32	125	Rc 1-1/2	65	122	230	97	40	14	
2	40	150	Rc 2	76	129	230	103.5	44	14	

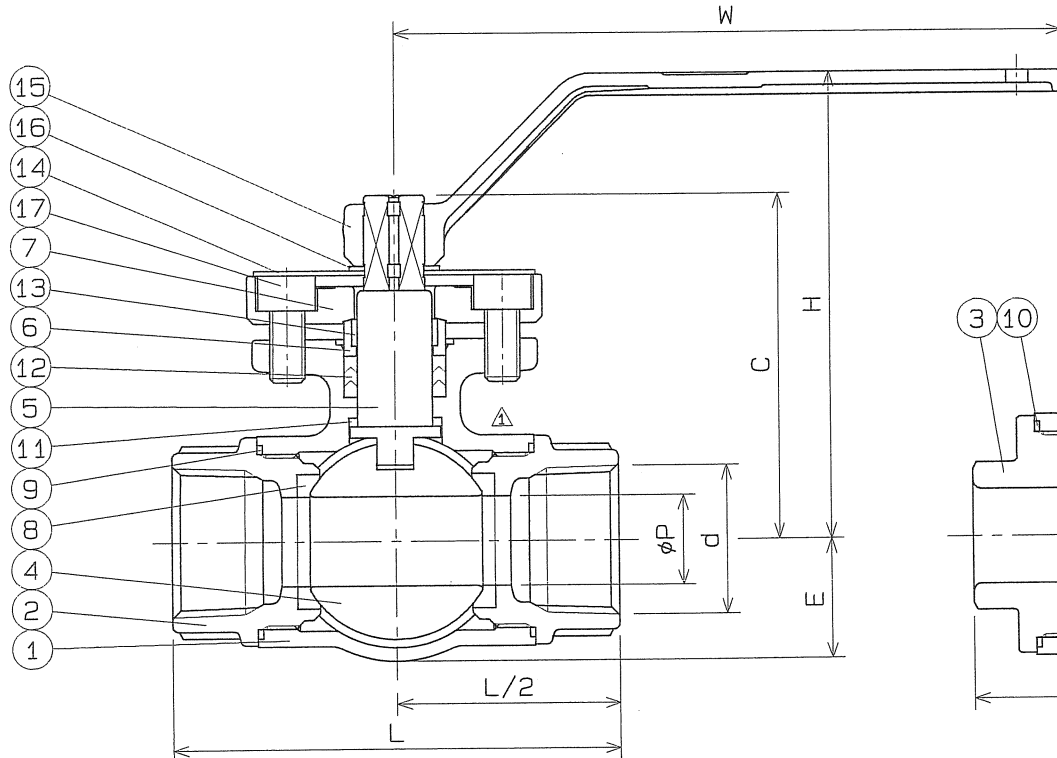

SPEC.		TEST PRESS.	
FLUID		SHELL	HYDRO 2.1 MPa (21.4 kgf/cm ²)
PRESS.	MPa (kgf/cm ²)	SEAT	AIR 0.6 MPa (6.1 kgf/cm ²)
TEMP.	°C	AIR	MPa (kgf/cm ²)

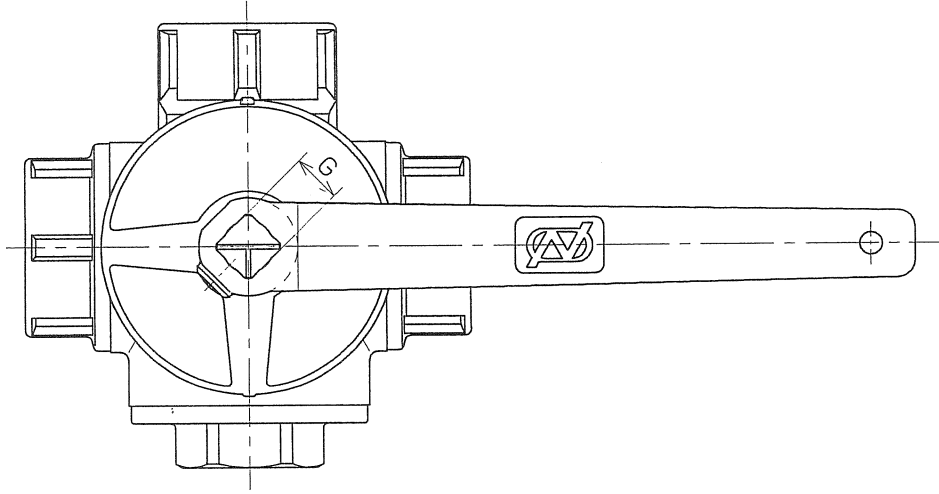
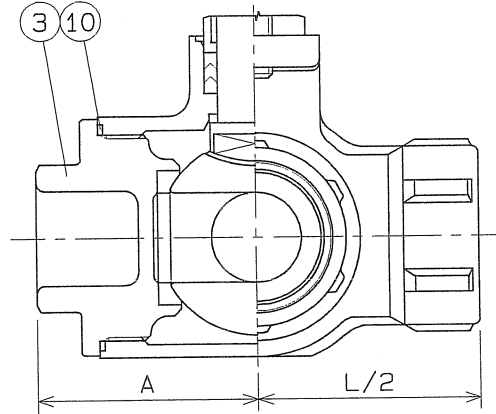

PIPE THREADS CONFORM WITH "JIS B 0203" TAPER THREADS

No.	NAME OF PARTS	Q. TY	MATERIALS	REMARKS
17	GLAND BOLT	2	SUS 304	
16	STOP RING	1	SUS 304	
15	HAND LEVER	1	SCS 13	
14	FLOW PLATE	1	A1050P	
13	STEM BEARING	1	P.T.F.E.	GLASS FILLED
12	GLAND PACKING	1SET	P.T.F.E.	
11	THRUST BEARING	1	P.T.F.E.	GLASS FILLED
10	GASKET PACKING	1	P.T.F.E.	
9	GASKET PACKING	2	P.T.F.E.	
8	BALL SEAT	4	P.T.F.E.	
7	GLAND	1	SCS 13	
6	GLAND SLEEVE	1	SUS 316	
5	STEM	1	SUS 304	
4	BALL DISC	1	SUS 304	
3	BLIND CAP	1	SCS 13	
2	BODY CAP	2	SCS 13	
1	BODY	1	SCS 13	

No.	NAME OF PARTS	Q. TY	MATERIALS	REMARKS
NAME JIS 10K SCREWED ENDS THREE WAY BALL VALVES				
TYPE N-730T		SIZE	1~2B	
DWG. No.	BATS-0901	APPROVED BY	<i>[Signature]</i>	
DATE	DEC. 2, 2004	CHECKED BY	<i>[Signature]</i>	
SCALE	:	DESIGNED BY	-	
THIRD ANGLE PROJECTION METHOD		DRAWN BY	<i>[Signature]</i>	

△	注釈の追加	'06. 3.13.
△	形状変更	'06. 2.16.

△ *SCS13製の部品はロスト・ワックス鋳造法で製造しています

O. N. INDUSTRIES LTD.