

◇ BAMS-0935 DMG.No.

SIZE	PIPE THREADS	P ₁	P ₂	L ₁	H ₁	W ₁	A ₁	D	Q, TY
	d ₁								
1/4	R 1/4	8	8	65.5	45	60	29	27	
3/8	R 3/8	8	8	65.5	45	60	29	27	
1/2	R 1/2	10	13	75	45	60	33	30.5	
3/4	R 3/4	15	18	81	49	60	35	38	
1	R 1	20	24	96.5	58	80	42.5	46.5	

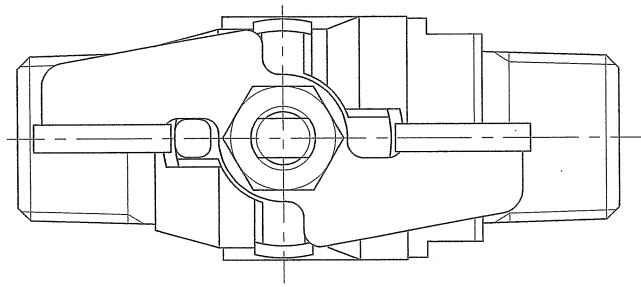

PVC COATING

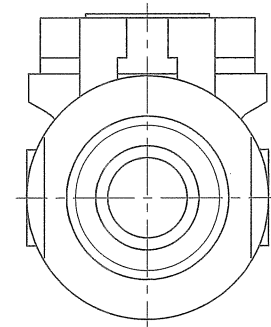
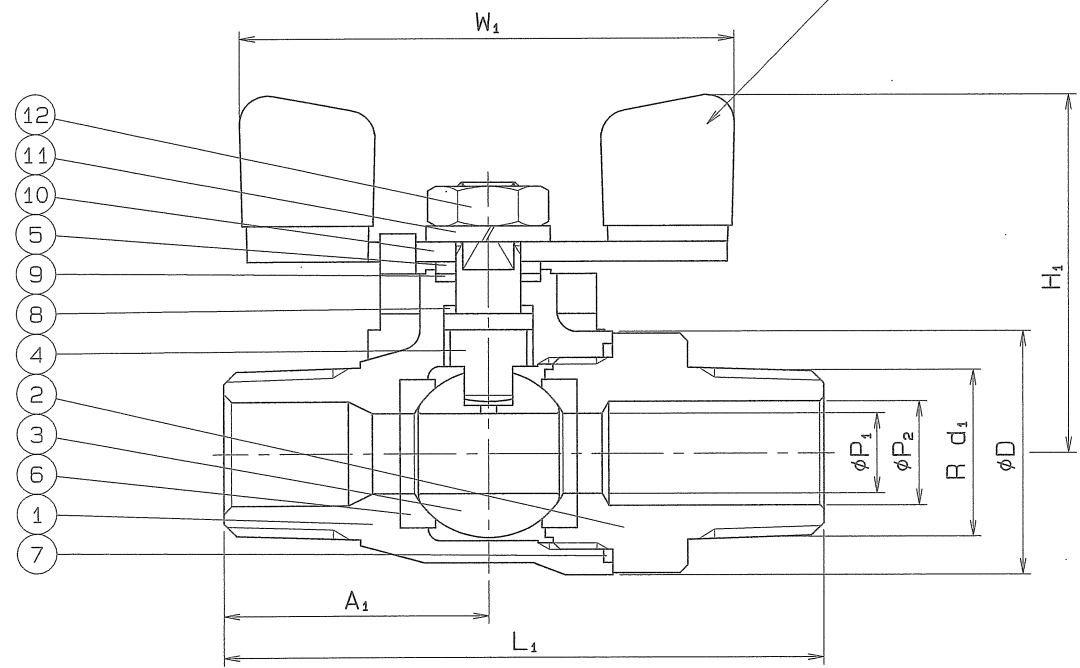

SPEC.		TEST PRESS.	
FLUID		SHELL	HYDRO 8.24 MPa (84 kgf/cm ²)
PRESS.	MPa (kgf/cm ²)	SEAT	AIR 0.6 MPa (6.1 kgf/cm ²)
TEMP.	°C		AIR MPa (kgf/cm ²)

PIPE THREADS CONFORM WITH 'JIS B 0203'
No.3 3/4, 1B MATERIALS : SCS 13A

No.	NAME OF PARTS	Q.TY	MATERIALS	REMARKS
12	HEXAGON NUT	1	SUS 304	
11	SPRING WASHER	1	SUS 304	
10	HANDLE	1	SUS 304	
9	THRUST BEARING	1	P.T.F.E.	CARBON FILLED
8	THRUST PACKING	1	P.T.F.E.	CARBON FILLED
7	GASKET PACKING	1	P.T.F.E.	
6	BALL SEAT	2	P.T.F.E.	
5	GLAND	1	SUS 316	
4	STEM	1	SUS 316	
3	BALL DISC	1	SUS 304	
2	BODY CAP	1	SUS 304	
1	BODY	1	SCS 13	

800 W.O.G.			
NAME MINI BALL VALVES			
TYPE	N-611M/M	SIZE	1/4 ~ 1 B
DMG.No.	BAMS-0935 ◇	APPROVED BY	K. Tsumoto
DATE	AUG. 27. 2007	CHECKED BY	K. Nakada
SCALE	:	DESIGNED BY	-
THIRD ANGLE PROJECTION METHOD		DRAWN BY K. Shiroka	

O. N. INDUSTRIES LTD.

△		
△		
△		