

09090-SWMB DNG. NO. BAMS-0609

SIZE	PIPE THREADS		P ₁	L ₂	H ₂	W ₂	A ₁	D	S	Q, TY
	d ₁	d ₂								
1/4	R 1/4	Rc 1/4	8	56.5	49	100	29	27	22	
3/8	R 3/8	Rc 3/8	8	56.5	49	100	29	27	22	

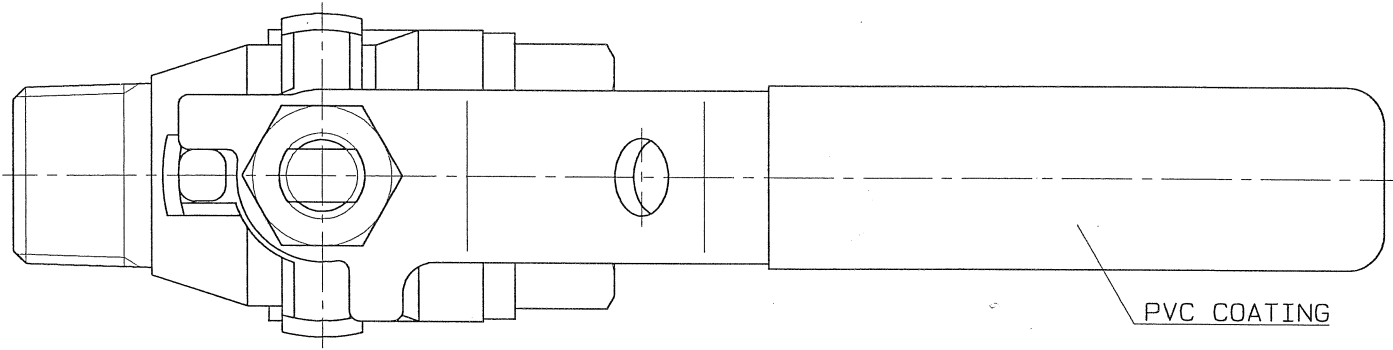

PVC COATING

SPEC.		TEST PRESS.	
FLUID		SHELL	HYDRO 8.24 MPa (84 kgf/cm ²)
PRESS.	MPa (kgf/cm ²)	SEAT	AIR 0.6 MPa (6.1 kgf/cm ²)
TEMP.	°C	AIR	MPa (kgf/cm ²)

- 12
- 11
- 10
- 5
- 9
- 8
- 4
- 1
- 3
- 6
- 2
- 7

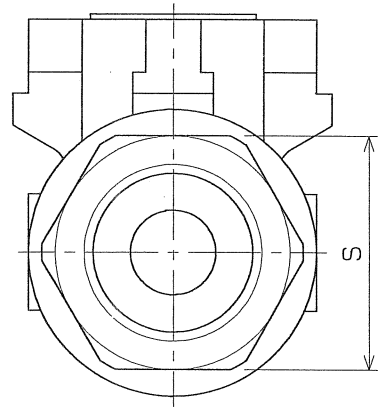
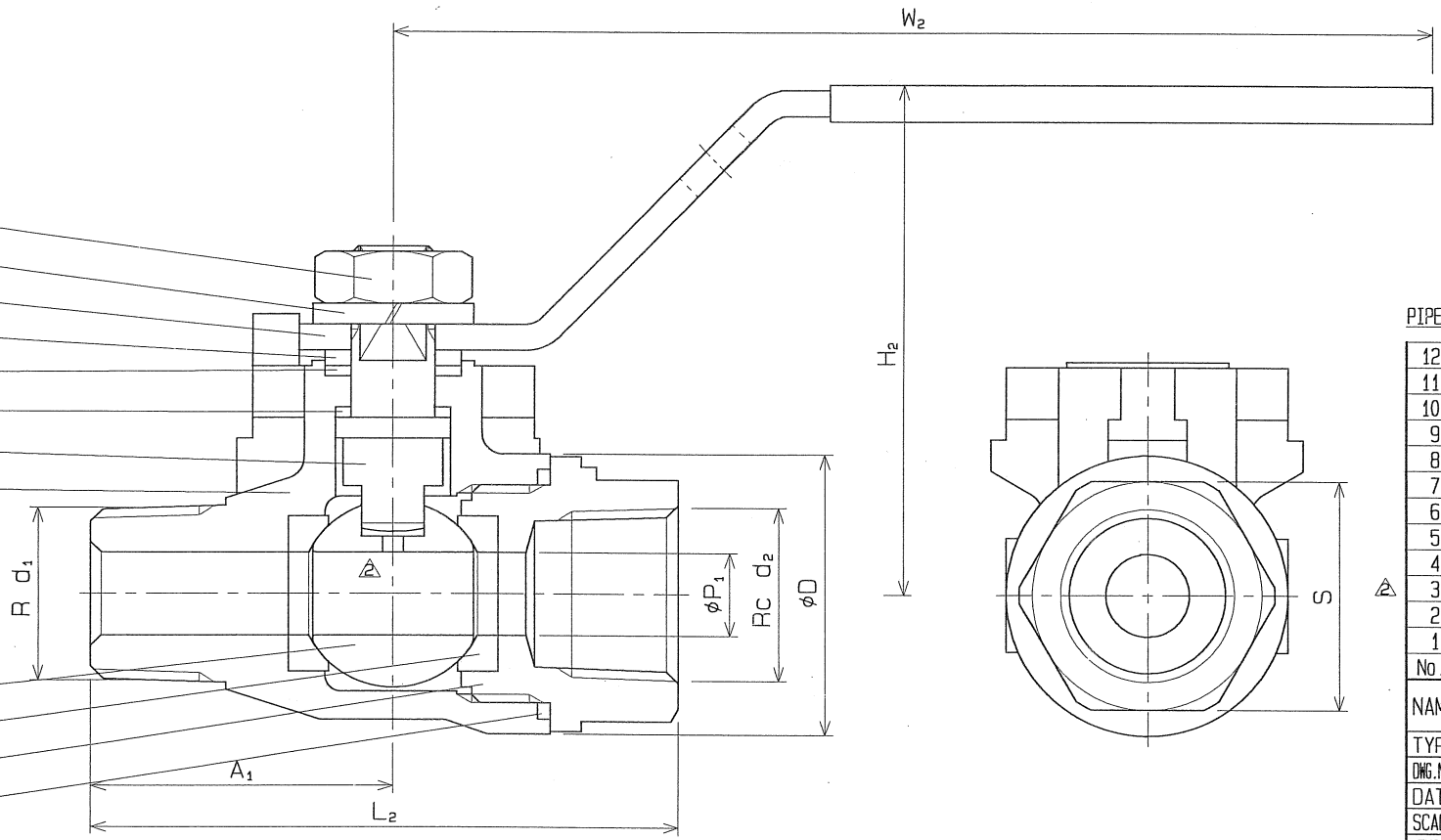

PIPE THREADS CONFORM WITH 'JIS B 0203'

No.	NAME OF PARTS	Q.TY	MATERIALS	REMARKS
12	HEXAGON NUT	1	SUS 304	
11	SPRING WASHER	1	SUS 304	
10	HANDLE	1	SUS 304	
9	THRUST BEARING	1	P.T.F.E.	CARBON FILLED
8	THRUST PACKING	1	P.T.F.E.	CARBON FILLED
7	GASKET PACKING	1	P.T.F.E.	
6	BALL SEAT	2	P.T.F.E.	
5	GLAND	1	SUS 316	
4	STEM	1	SUS 316	
3	BALL DISC	1	SUS 304	
2	BODY CAP	1	SCS 13	
1	BODY	1	SCS 13	

NAME 800 W.O.G. MINI BALL VALVES			
TYPE	N-611M/F	SIZE	1/4, 3/8 B
DWG. No.	BAMS-0609	APPROVED BY	<i>K. Funata</i>
DATE	MAY. 14. 1993	CHECKED BY	<i>A. Ashida</i>
SCALE	:	DESIGNED BY	
THIRD ANGLE PROJECTION METHOD		DRAWN BY	<i>K. Takai</i>

△	リリーフホールの追加	'03.10.21.
△	ST単位に変更	'99. 5.27.

O. N. INDUSTRIES LTD.