

MATERIAL : SCS 13, SCS 14

SIZE	PIPE THREADS	L	A	B	Q, TY
	d				
1 ¹ / ₄	1 ¹ / ₄	17	34	51	
1 ¹ / ₂	1 ¹ / ₂	18	37	58.5	
2	2	20	42	71	
2 ¹ / ₂	2 ¹ / ₂	23	49	88.5	
3	3	25	54	102	
4	4	28	64	130	

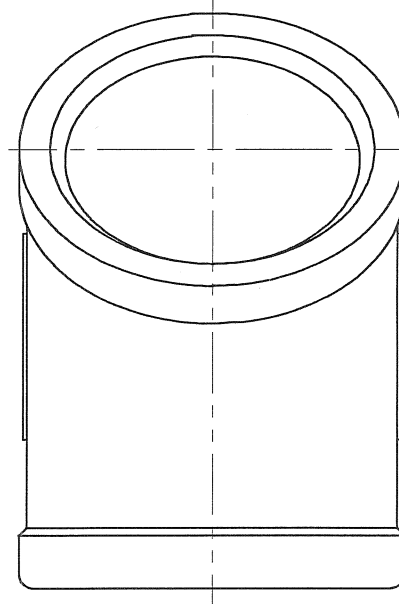
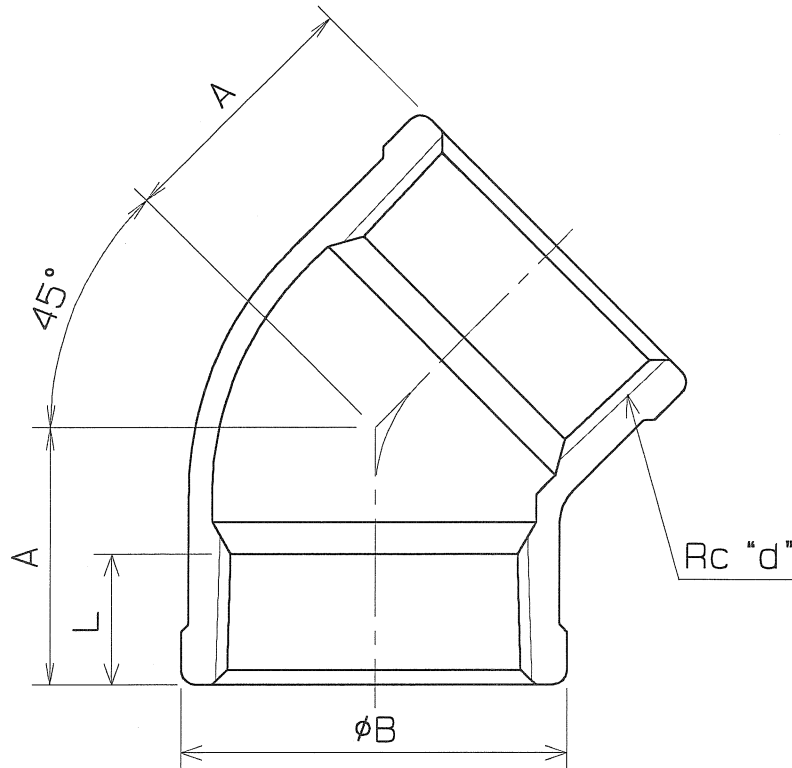

PIPE THREADS CONFORM WITH 'JIS B 0203'

SPEC.		TEST PRESSURE	
FLUID		SHELL	AIR 0.6 MPa (6.1 kgf/cm ²)
PRESS.	MPa (kgf/cm ²)	AIR	MPa (kgf/cm ²)
TEMP.	°C	AIR	MPa (kgf/cm ²)

NAME	45° ELBOW	
TYPE	-	SIZE 1 ¹ / ₄ ~ 4 B \triangle
DRG.No.	JADV-0025 \oplus	APPROVED BY <i>H. Yamamoto</i>
DATE	AUG. 21. 2000	CHECKED BY <i>H. Adachi</i>
SCALE	:	DESIGNED BY <i>R. Matsuki</i>
THIRD ANGLE PROJECTION METHOD		DRAWN BY

\triangle	寸法訂正 (52→54)	H18. 1.10.	松本
\triangle	2 1/2~4B追加、検査圧力の変更	H16. 4.29.	高井
符号	訂正事由	年.月.日.	訂正者

O. N. INDUSTRIES LTD.