

SIZE	PIPE THREADS	A	C	I	J	S	Q, TY
	d						
1/2	1/2	40	14.5	16	8	24	
3/4	3/4	44	20	18	8	29	
1	1	52	25.5	21	10	36	
1 1/4	1 1/4	56	33.5	23	10	46	
1 1/2	1 1/2	60	39	24	12	54	
2	2	66	50	27	12	63	
2 1/2	2 1/2	73	64.5	30	13	80	
3	3	81	76	34	13	95	
4	4	92	100	39.5	13	120	

MATERIAL : SCS 13, SCS 14

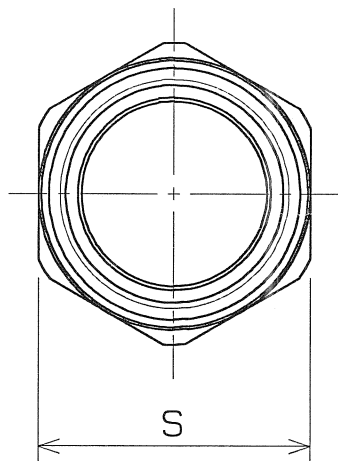
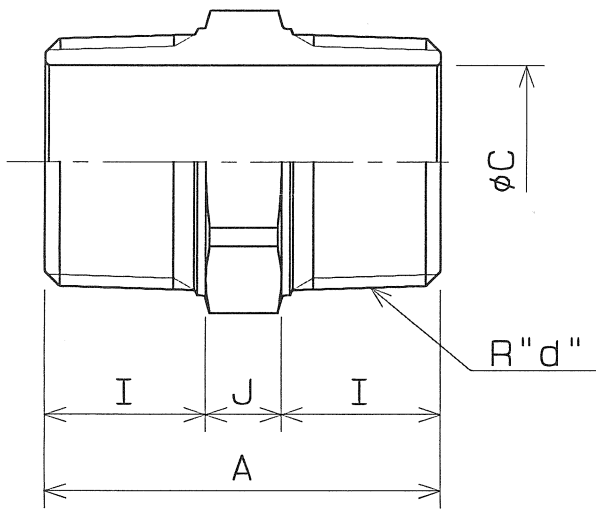

PIPE THREADS CONFORM WITH 'JIS B 0203'

SPEC.		TEST PRESSURE	
FLUID		SHELL	AIR 0.6 MPa (6.1 kgf/cm ²)
PRESS.	MPa (kgf/cm ²)		MPa (kgf/cm ²)
TEMP.	°C		MPa (kgf/cm ²)

NAME				HEXAGON NIPPLE			
TYPE	-			SIZE	1/2 ~ 4 B		
DRG.No.	JADN-0031	APPROVED BY	<i>R. Yamada</i>				
DATE	JUN. 5. 1997	CHECKED BY	<i>H. Asakura</i>				
SCALE	:	DESIGNED BY	<i>R. Matsuki</i>				
THIRD ANGLE PROJECTION METHOD				DRAWN BY	<i>R. Matsuki</i>		

△	寸法変更 (1~2B)	H16. 7.16.
△	呼び径追加	H16. 3.11.
△	呼び径削除 (2 1/2~4)	H15. 8.30.
△	検査圧力の変更	H11. 5.10.

O. N. INDUSTRIES LTD.