

SPEC.		TEST PRESS.	
FLUID		SHELL	HYDRO 3.5 MPa (35.7 kgf/cm <sup>2</sup> )
△ PRESS.	MAX 2.0 MPa (20.4 kgf/cm <sup>2</sup> )	SEAT	AIR 0.6 MPa (6.1 kgf/cm <sup>2</sup> )
△ TEMP.	MAX 100°C	AIR	MPa ( kgf/cm <sup>2</sup> )

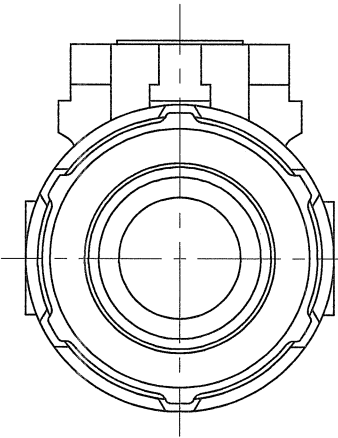
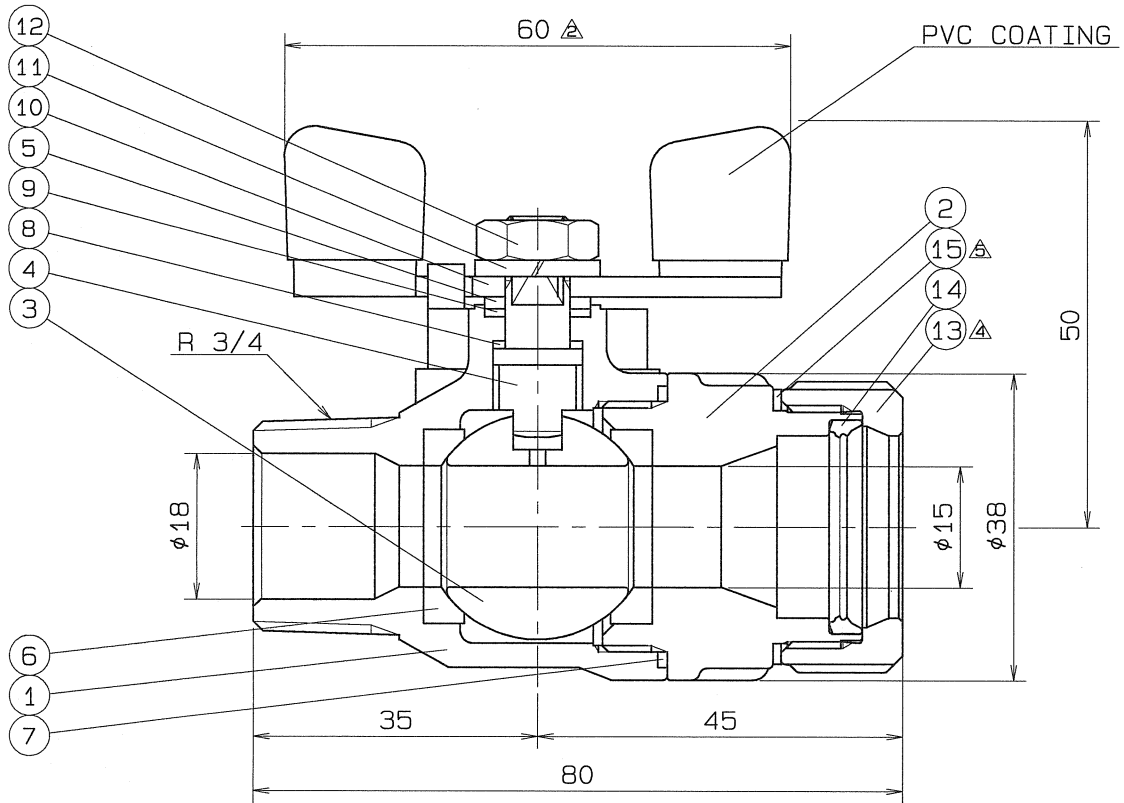

PIPE THREADS CONFORM WITH 'JIS B 0203'  
 △ \*SPECIAL TEFLON

No.	NAME OF PARTS	Q.TY	MATERIALS	REMARKS
15	CONICAL WASHER	1	JFE443CT	
14	RUBBER PACKING	1	SYNTHETIC RUBBER (HNBR)	
13	NUT	1	SCS 13	
12	HEXAGON NUT	1	SUS 304	
11	SPRING WASHER	1	SUS 304	
10	HANDLE	1	SUS 304	
9	THRUST BEARING	1	P.T.F.E.	CARBON FILLED
8	THRUST PACKING	1	P.T.F.E.	CARBON FILLED
7	GASKET PACKING	1	P.T.F.E.	
6	BALL SEAT	2	P.T.F.E.	*
5	GLAND	1	SUS 316	
4	STEM	1	SUS 316	
3	BALL DISC	1	SCS 13A	
2	BODY CAP	1	SCS 13	
1	BODY	1	SCS 13	

NAME	NICE JOINT AND SCREWED ENDS MINI BALL VALVES		
TYPE	NJ-611	SIZE	20SuX3/4B
DMG.No.	BAMS-0914	APPROVED BY	<i>[Signature]</i>
DATE	OCT. 28. 2006	CHECKED BY	<i>[Signature]</i>
SCALE	:	DESIGNED BY	—
THIRD ANGLE PROJECTION METHOD	DRAWN BY <i>[Signature]</i>		

△ 使用圧力、使用温度追加	H24. 1. 13.
△ 検査圧力の変更	H23. 2. 9.
△ 皿ワッシャ材質変更	H22. 2. 10.