

DMG.No. BAMS-0851

SIZE	d	P	L	L ₁	L ₂	H	W	D	Q, TY
20Su x 3/4	Rc 3/4	15	80	45	35	91	100	38	
25Su x 1	Rc 1	20	88.5	48.5	40	101	130	47	

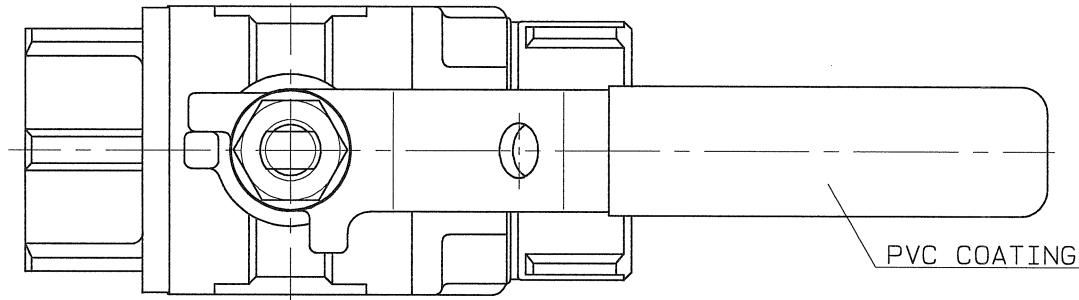

SPEC.		TEST PRESS.	
FLUID		SHELL	HYDRO 3.5 MPa (35.7 kgf/cm ²)
△ PRESS.	MAX 2.0 MPa (20.4 kgf/cm ²)	SEAT	AIR 0.6 MPa (6.1 kgf/cm ²)
△ TEMP.	MAX 100°C		AIR (MPa kgf/cm ²)

PIPE THREADS CONFORM WITH "JIS B 0203"
 △ *SPECIAL TEFLON

19	PLAIN WASHER	1	SUS 304	
18	O RING	1	VITON	
△ 17	CONICAL WASHER	1	JFE443CT	
16	RUBBER PACKIG	1	SYNTHETIC RUBBER (HNBR)	
△ 15	NUT	1	SCS 13	
14	HEXAGON NUT	1	SUS 304	
13	SPRING WASHER	1	SUS 304	
12	HANDLE	1	SUS 304	
11	GLAND PACKING	1	P.T.F.E.	
10	BEARING	1	P.T.F.E.	CARBON FILLED
9	GASKET PACKING	2	P.T.F.E.	
△ 8	BALL SEAT	2	P.T.F.E.	*
7	WASHER	1	SUS 304CSP	
△ 6	GLAND BUSHING	1	SCS 13	
5	STEM	1	SUS 304	
△ 4	BALL DISC	1	SCS 13A	△
3	BODY CAP (B)	1	SCS 13	Rc d
2	BODY CAP (A)	1	SCS 13	
1	BODY	1	SCS 13	

No.	NAME OF PARTS	Q. TY	MATERIALS	REMARKS
NAME	NICE JOINT AND SCREWED ENDS REDUCED BORE LONG NECK TYPE MINI BALL VALVES			
TYPE	△ NJ-202NF	SIZE	20, 25Su	
DMG.No.	BAMS-0851	APPROVED BY	<i>[Signature]</i>	
DATE	JAN. 21. 2002	CHECKED BY	<i>[Signature]</i>	
SCALE	:	DESIGNED BY	—	
THIRD ANGLE PROJECTION METHOD		DRAWN BY <i>[Signature]</i>		

O. N. INDUSTRIES LTD.

- 14
- 13
- 19
- 12
- 6
- 7
- 11
- 10
- 18
- 5
- 9
- 4
- 8
- 1
- 3

- △ 2
- △ 17
- △ 16
- △ 15

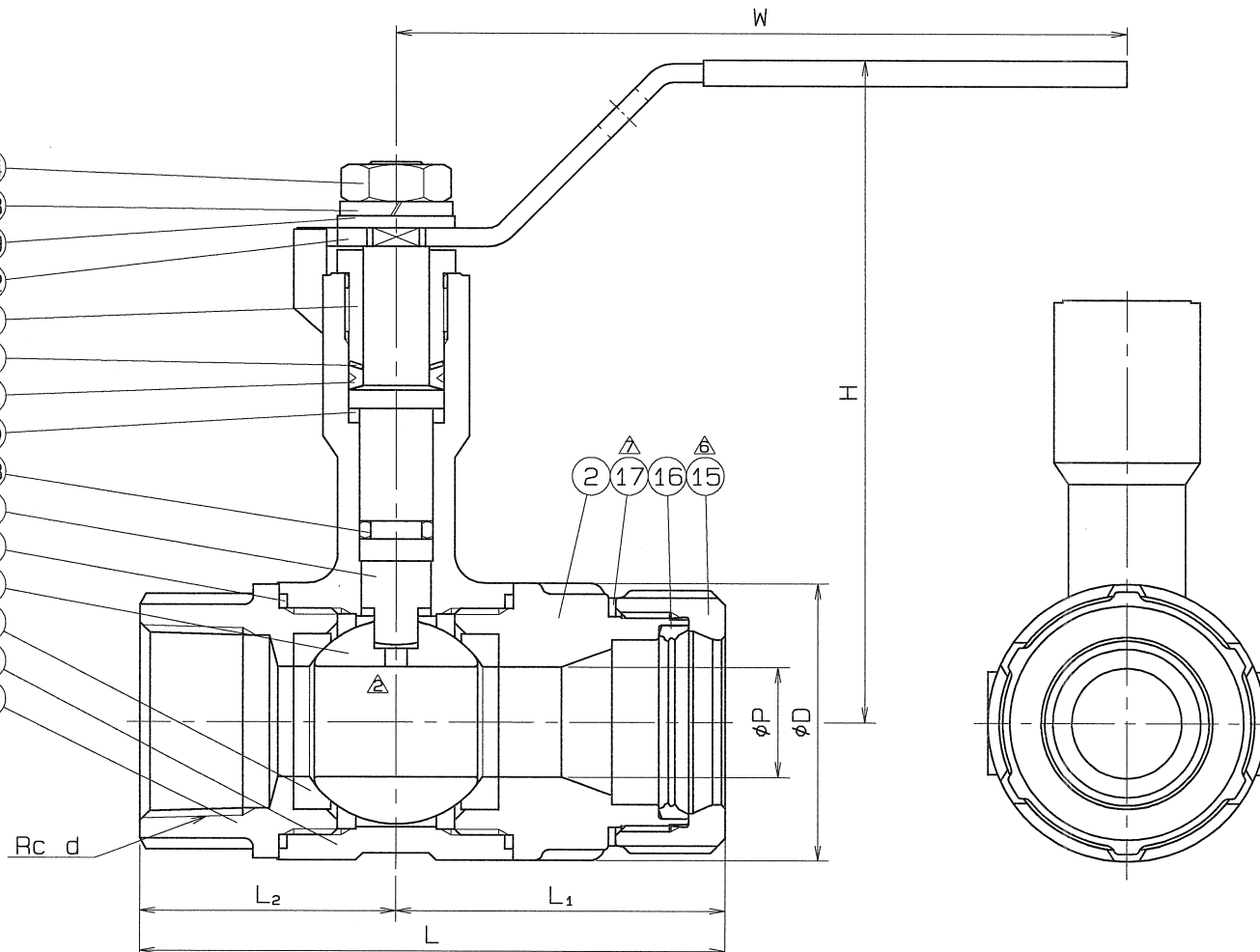

△ 使用圧力, 使用温度追加	H24. 1. 13.
△ 検査圧力の変更	H23. 2. 9.
△ 鋼ワッシャ材質変更	H22. 2. 10.