

◇ 9000-SWABX 'ON' OMO

SIZE	P	L <sub>1</sub>	L <sub>2</sub>	H <sub>1</sub>	H <sub>2</sub>	W	D	Q. TY
13 Su	15	83	75	91	45	100	38	
20 Su	20	95	85	101	46	130	46.5	
25 Su	25	99	87	104	46	130	54	

SPEC.		TEST PRESS.	
FLUID		SHELL	HYDRO 3.5 MPa
PRESS.	MAX 2.0 MPa	SEAT	AIR 0.6 MPa
TEMP.	MAX 100 ℃		AIR MPa

\*MODIFIED P.T.F.E.

No.	NAME OF PARTS	Q. TY	MATERIALS	REMARKS
17	O RING	1	FKM	
16	LOOSE STOPPER	2	SUS 304CSP	
15	RUBBER PACKIG	2	SYNTHETIC RUBBER (HNBR)	
14	RATCHET NUT	2	SCS 13	
13	HEXAGON NUT	1	SUS 304	
12	SPRING WASHER	1	SUS 304	
11	HANDLE	1	SUS 304	
10	GLAND PACKING	1	P.T.F.E.	
9	BEARING	1	P.T.F.E.	CARBON FILLED
8	GASKET PACKING	2	P.T.F.E.	
7	BALL SEAT	2	P.T.F.E.	*
6	WASHER	1	SUS 304CSP	
5	GLAND BUSHING	1	SCS 13	
4	STEM	1	SUS 304	
3	BALL DISC	1	SCS 13A	
2	BODY CAP	2	SCS 13	
1	BODY	1	SCS 13	

NAME NICE JOINT ENDS FULL BORE LONG NECK TYPE MINI BALL VALVES			
TYPE	NJX-220	SIZE	13~25Su
DMG.No.	XBAMS-0006◇	APPROVED BY	H. Ogawa
DATE	MAR. 14. 2023	CHECKED BY	H. Ogawa
SCALE	:	DESIGNED BY	M. Yamashima
THIRD ANGLE PROJECTION METHOD		DRAWN BY	T. Okamoto

**O. N. INDUSTRIES LTD.**

③		
②		
①		

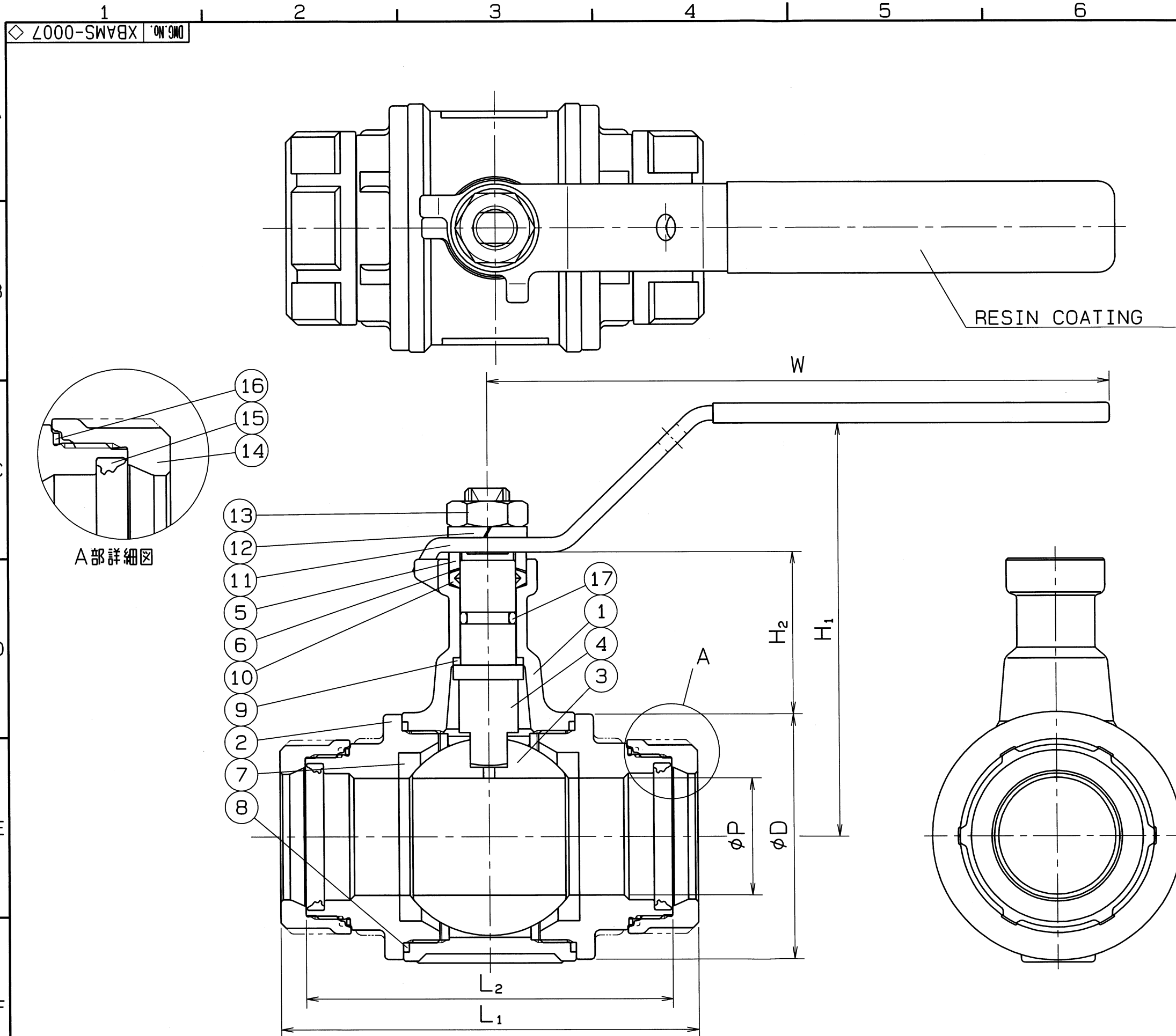

SIZE	P	L <sub>1</sub>	L <sub>2</sub>	H <sub>1</sub>	H <sub>2</sub>	W	D	Q, TY
30 Su	32	114	100	119	44	170	67	
40 Su	40	125	107	125	43	170	80	

SPEC.		TEST PRESS.	
FLUID		SHELL	HYDRO 3.5 MPa
PRESS.	MAX 2.0 MPa	SEAT	AIR 0.6 MPa
TEMP.	MAX 100 ℃		AIR MPa

\*MODIFIED P.T.F.E.

No.	NAME OF PARTS	Q.TY	MATERIALS	REMARKS
17	O RING	1	FKM	
16	LOOSE STOPPER	2	SUS 304CSP	
15	RUBBER PACKING	2	SYNTHETIC RUBBER (HNBR)	
14	RATCHET NUT	2	SCS 13	
13	HEXAGON NUT	1	SUS 304	
12	SPRING WASHER	1	SUS 304	
11	HANDLE	1	SUS 304	
10	GLAND PACKING	1	P.T.F.E.	
9	BEARING	1	P.T.F.E.	CARBON FILLED
8	GASKET PACKING	2	P.T.F.E.	
7	BALL SEAT	2	P.T.F.E.	*
6	WASHER	1	SUS 304CSP	
5	GLAND BUSHING	1	SUS 304	
4	STEM	1	SUS 304	
3	BALL DISC	1	SCS 13A	
2	BODY CAP	2	SCS 13	
1	BODY	1	SCS 13	

NAME	NICE JOINT ENDS FULL BORE LONG NECK TYPE MINI BALL VALVES		
TYPE	NJX-220	SIZE	30, 40Su
DWG.No.	XBAMS-0007◇	APPROVED BY	H. Ogura
DATE	MAR. 14. 2023	CHECKED BY	H. Ogura
SCALE	:	DESIGNED BY	M. Yamashima
THIRD ANGLE PROJECTION METHOD		DRAWN BY	T. Okamoto

**O. N. INDUSTRIES LTD.**

△		
△		
△		

◇ 8000-SWABX 'ON' QMO

Q.TY :

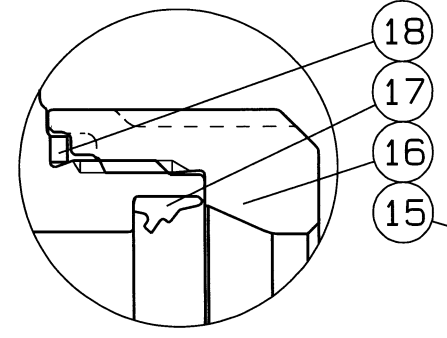

A部詳細図

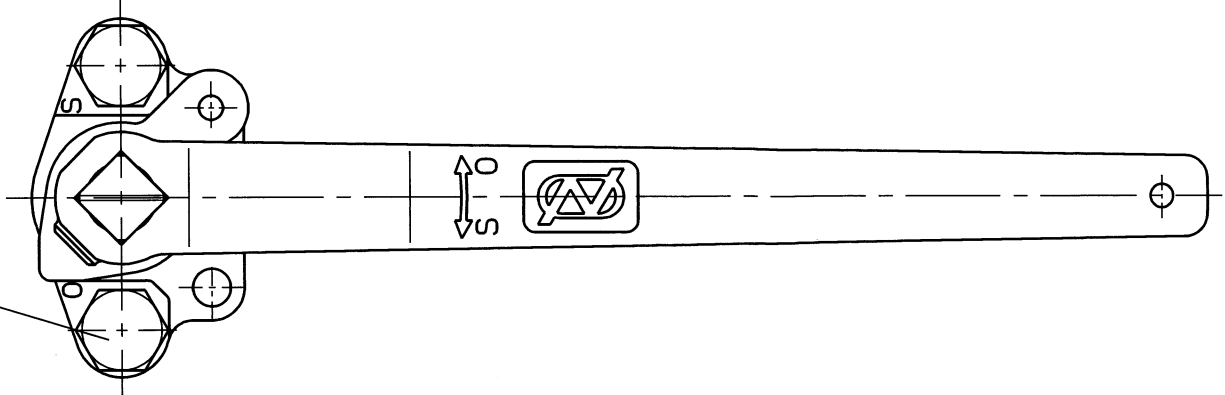

SPEC.		TEST PRESS.	
FLUID		SHELL	HYDRO 3.5 MPa
PRESS.	MAX 2.0 MPa	SEAT	AIR 0.6 MPa
TEMP.	MAX 100 °C	AIR	MPa

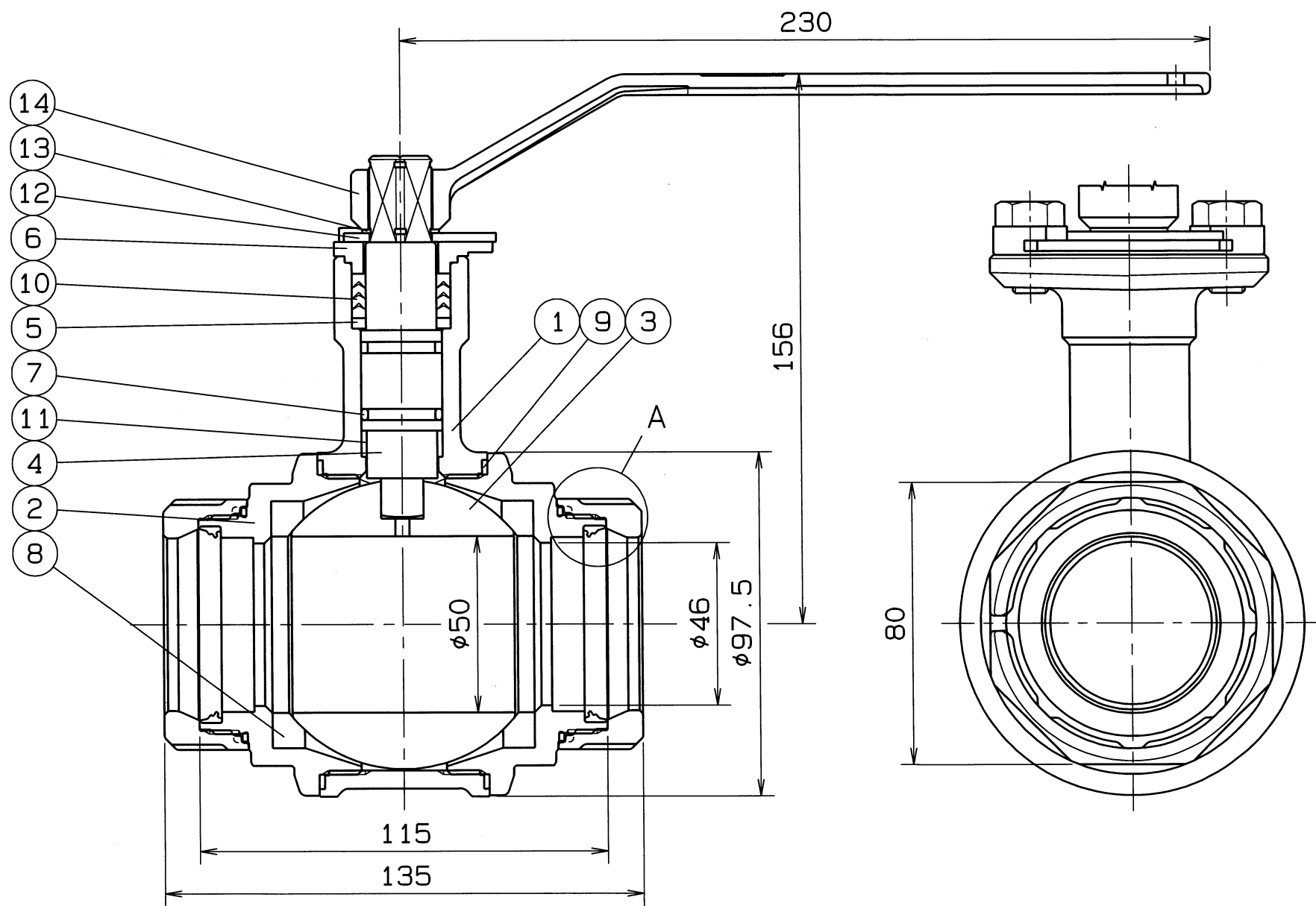

\*MODIFIED P.T.F.E.

No.	NAME OF PARTS	Q.TY	MATERIALS	REMARKS
18	LOOSE STOPPER	2	SUS 304CSP	
17	RUBBER PACKING	2	SYNTHETIC RUBBER (HNBR)	
16	RATCHET NUT	2	SCS 13	
15	GLAND BOLT	2	SUS 304	
14	HANDLE	1	SCS 13	
13	STOP RING	1	SUS 304	
12	STOPPER	1	SUS 304	
11	STEM BEARING	1	P.T.F.E.	GLASS FILLED
10	GLAND PACKING	1SET	P.T.F.E.	
9	GASKET PACKING	2	P.T.F.E.	
8	BALL SEAT	2	P.T.F.E.	*
7	O RING	2	FKM	P18
6	GLAND	1	SCS 13	
5	THRUST RING	1	SUS 329J1	
4	STEM	1	SUS 304	
3	BALL DISC	1	SCS 13A	
2	BODY CAP	2	SCS 13	
1	BODY	1	SCS 13	

NAME	NICE JOINT ENDS LONG NECK TYPE MINI BALL VALVE		
TYPE	NJX-220	SIZE	50Su
DMG.No.	XBAMS-0008◇	APPROVED BY	H.Ogawa
DATE	MAR. 14. 2023.	CHECKED BY	H.Ogawa
SCALE	:	DESIGNED BY	M.Yamashima
THIRD ANGLE PROJECTION METHOD		DRAWN BY	T.Okamoto

**O. N. INDUSTRIES LTD.**

△		
△		
△		