

SIZE	P	L ₁	L ₂	H ₁	H ₂	W	D	Q. TY
13 Su	10	78	70	87	44	100	33	
20 Su	15	90	80	91	45	100	38	
25 Su	20	97	85	101	46	130	47	
30 Su	20	99	85	101	42	130	54	
40 Su	25	108	90	104	41	130	64	

SPEC.		TEST PRESS.	
FLUID		SHELL	HYDRO 3.5 MPa
PRESS.	MAX 2.0 MPa	SEAT	AIR 0.6 MPa
TEMP.	MAX 100 ℃	AIR	MPa

No.3 13Su MATERIAL : SUS 304
*MODIFIED P.T.F.E.

No.	NAME OF PARTS	Q.TY	MATERIALS	REMARKS
17	O RING	1	FKM	
16	LOOSE STOPPER	2	SUS 304CSP	
15	RUBBER PACKIG	2	SYNTHETIC RUBBER (HNBR)	
14	RATCHET NUT	2	SCS 13	
13	HEXAGON NUT	1	SUS 304	
12	SPRING WASHER	1	SUS 304	
11	HANDLE	1	SUS 304	
10	GLAND PACKING	1	P.T.F.E.	
9	BEARING	1	P.T.F.E.	CARBON FILLED
8	GASKET PACKING	2	P.T.F.E.	
7	BALL SEAT	2	P.T.F.E.	*
6	WASHER	1	SUS 304CSP	
5	GLAND BUSHING	1	SCS 13	
4	STEM	1	SUS 304	
3	BALL DISC	1	SCS 13A	
2	BODY CAP	2	SCS 13	
1	BODY	1	SCS 13	

NAME	NICE JOINT ENDS REDUCED BORE LONG NECK TYPE MINI BALL VALVES		
TYPE	NJX-200	SIZE	13~40Su
DMG.No.	XBAMS-0001◇	APPROVED BY	H. Ogura
DATE	MAR. 14. 2023	CHECKED BY	H. Ogura
SCALE	:	DESIGNED BY	M. Yamashina
THIRD ANGLE PROJECTION METHOD		DRAWN BY	T. Okamoto

O. N. INDUSTRIES LTD.

SIZE	P	L ₁	L ₂	H ₁	H ₂	W	D	Q. TY
50 Su	32	125	105	119	41	170	72	
60 Su	40	139	115	125	40	170	87	

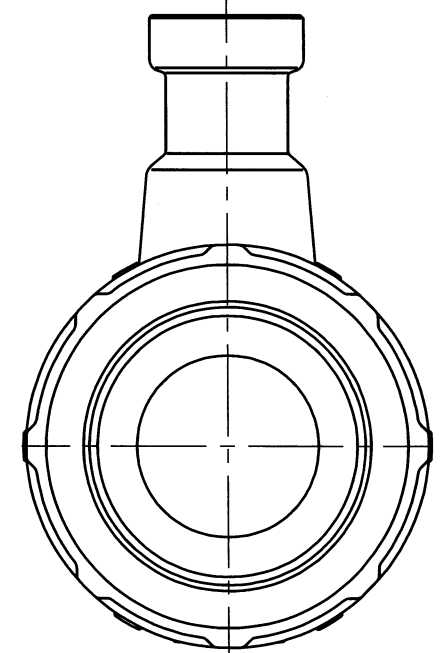
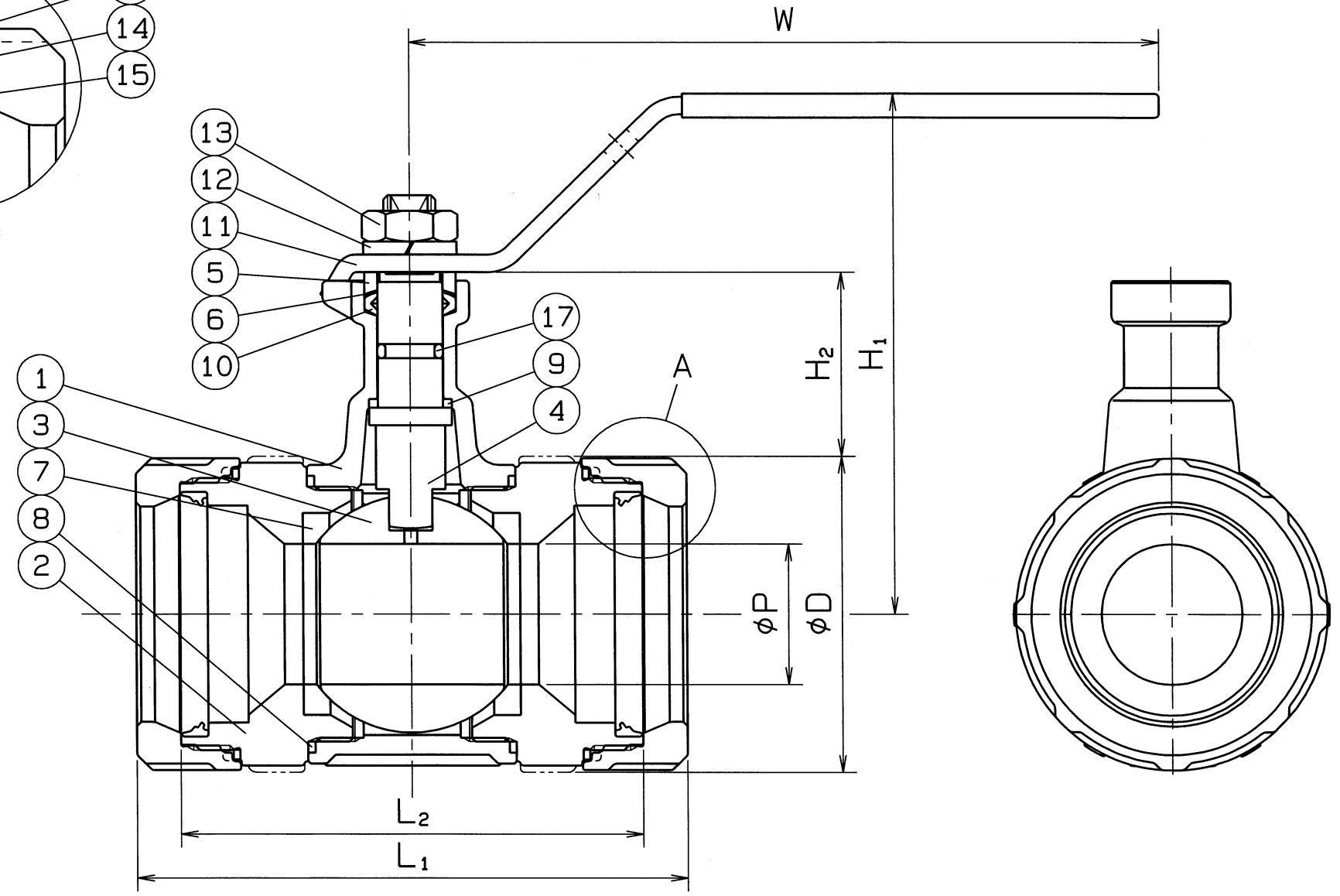
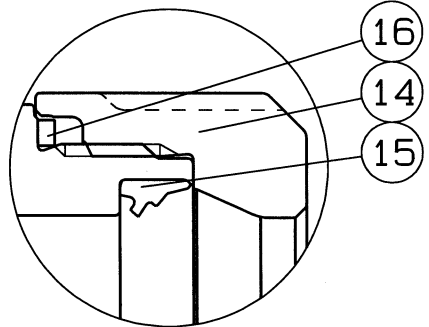
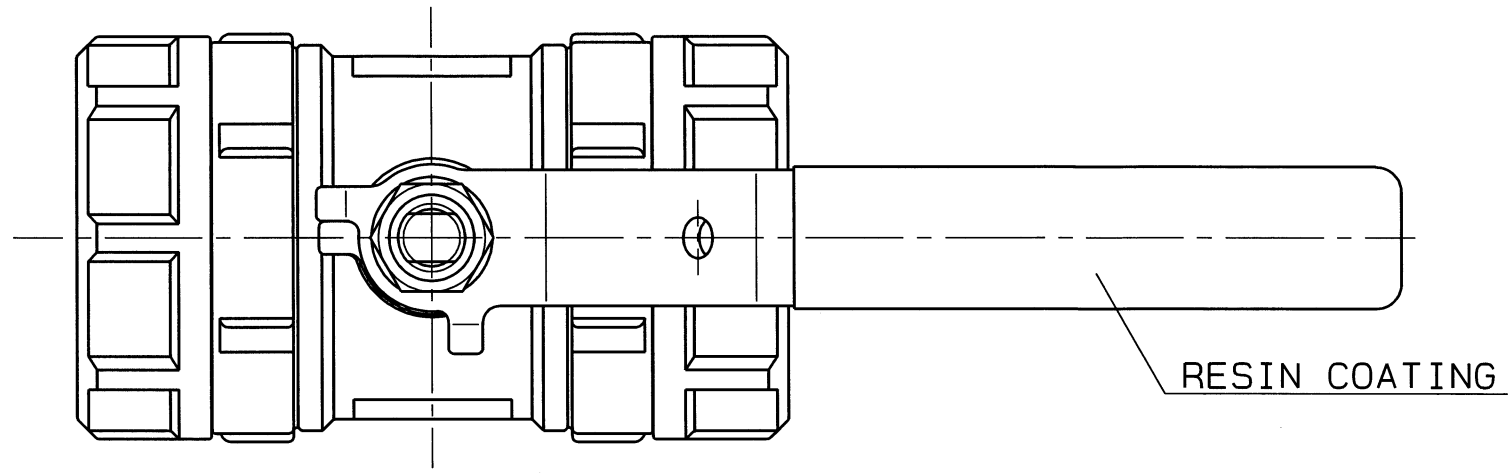

SPEC.		TEST PRESS.		
FLUID		SHELL	HYDRO	3.5 MPa
PRESS.	MAX 2.0 MPa	SEAT	AIR	0.6 MPa
TEMP.	MAX 100 ℃		AIR	MPa

*MODIFIED P.T.F.E.

No.	NAME OF PARTS	Q.TY	MATERIALS	REMARKS
17	O RING	1	FKM	
16	LOOSE STOPPER	2	SUS 304CSP	
15	RUBBER PACKING	2	SYNTHETIC RUBBER (HNBR)	
14	RATCHET NUT	2	SCS 13	
13	HEXAGON NUT	1	SUS 304	
12	SPRING WASHER	1	SUS 304	
11	HANDLE	1	SUS 304	
10	GLAND PACKING	1	P.T.F.E.	
9	BEARING	1	P.T.F.E.	CARBON FILLED
8	GASKET PACKING	2	P.T.F.E.	
7	BALL SEAT	2	P.T.F.E.	*
6	WASHER	1	SUS 304CSP	
5	GLAND BUSHING	1	SUS 304	
4	STEM	1	SUS 304	
3	BALL DISC	1	SCS 13A	
2	BODY CAP	2	SCS 13	
1	BODY	1	SCS 13	

NAME	NICE JOINT ENDS REDUCED BORE LONG NECK TYPE MINI BALL VALVES		
TYPE	NJX-200	SIZE	50, 60 Su
DATE	MAR. 14, 2023	CHECKED BY	H. Ogura
SCALE	:	DESIGNED BY	M. Yamashima
THIRD ANGLE PROJECTION METHOD	DRAWN BY T. Okamoto		

△		
△		
△		