

NJSR

SPEC.		TEST PRESS.	
FLUID		SHELL	HYDRO 3.5 MPa
PRESS.	MAX 2.0 MPa	SEAT	AIR 0.6 MPa
TEMP.	MAX 100 °C	AIR	MPa

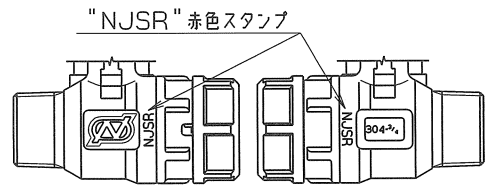

外観図

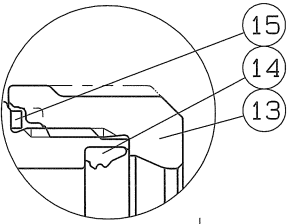

A部詳細図

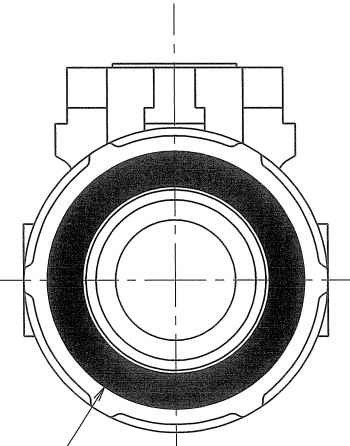
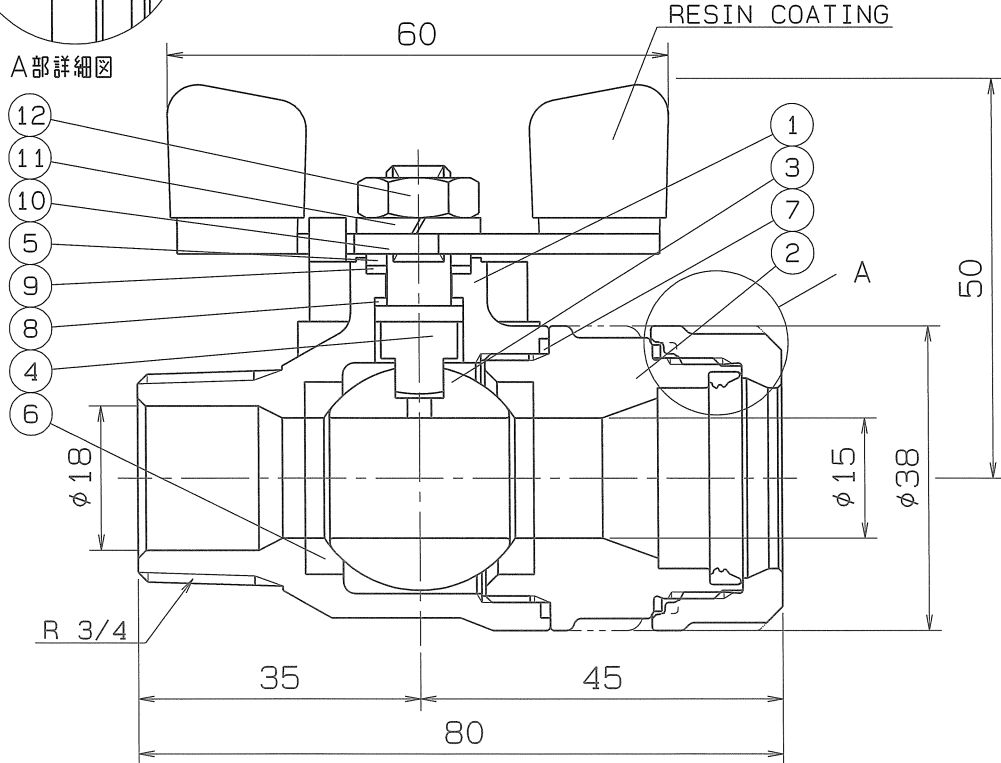

ナット端面赤色スタンプ

PIPE THREADS CONFORM WITH "JIS B 0203"
*MODIFIED P.T.F.E.

No.	NAME OF PARTS	Q. TY	MATERIALS	REMARKS
15	LOOSE STOPPER	1	SUS 304CSP	
14	RUBBER PACKING	1	SYNTHETIC RUBBER (NJSR)	
13	RATCHET NUT	1	SCS 13	
12	HEXAGON NUT	1	SUS 304	
11	SPRING WASHER	1	SUS 304	
10	HANDLE	1	SUS 304	
9	THRUST BEARING	1	P.T.F.E.	CARBON FILLED
8	THRUST PACKING	1	P.T.F.E.	CARBON FILLED
7	GASKET PACKING	1	P.T.F.E.	
6	BALL SEAT	2	P.T.F.E.	*
5	GLAND	1	SUS 316	
4	STEM	1	SUS 316	
3	BALL DISC	1	SCS 13A	
2	BODY CAP	1	SCS 13	
1	BODY	1	SCS 13	

No.	NAME OF PARTS	Q. TY	MATERIALS	REMARKS
NAME NICE JOINT AND SCREWED ENDS MINI BALL VALVES				
TYPE NJX-611		SIZE 20Su x 3/4B		
DNG.No. XBAMS-0033◇		DATE NOV. 6. 2023		

APPROVED	DESIGNED	CHECKED	DRAWN
