

NJSR

SPEC.		TEST PRESS.	
FLUID		SHELL	HYDRO 3.5 MPa
PRESS.	MAX 2.0 MPa	SEAT	AIR 0.6 MPa
TEMP.	MAX 100 °C	AIR	MPa

"NJSR" 赤色スタンプ

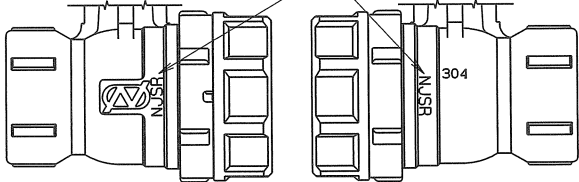

外観図

PIPE THREADS CONFORM WITH "JIS B 0203"
*MODIFIED P.T.F.E.

No.	NAME OF PARTS	Q.TY	MATERIALS	REMARKS
15	LOOSE STOPPER	1	SUS 304CSP	
14	RUBBER PACKING	1	SYNTHETIC RUBBER (NJSR)	
13	RATCHET NUT	1	SCS 13	
12	HEXAGON NUT	1	SUS 304	
11	SPRING WASHER	1	SUS 304	
10	HANDLE	1	SUS 304	
9	THRUST BEARING	1	P.T.F.E.	CARBON FILLED
8	THRUST PACKING	1	P.T.F.E.	CARBON FILLED
7	GASKET PACKING	1	P.T.F.E.	
6	BALL SEAT	2	P.T.F.E.	*
5	GLAND	1	SUS 316	
4	STEM	1	SUS 316	
3	BALL DISC	1	SCS 13A	
2	BODY CAP	1	SCS 13	
1	BODY	1	SCS 13	

NAME	NICE JOINT AND SCREWED ENDS MINI BALL VALVES		
TYPE	NJX-610	SIZE	40 Su
DMG.No.	XBAMS-0031	DATE	NOV. 6. 2023

APPROVED	DESIGNED	CHECKED	DRAWN

THIRD ANGLE PROJECTION METHOD SCALE :
O. N. INDUSTRIES LTD.

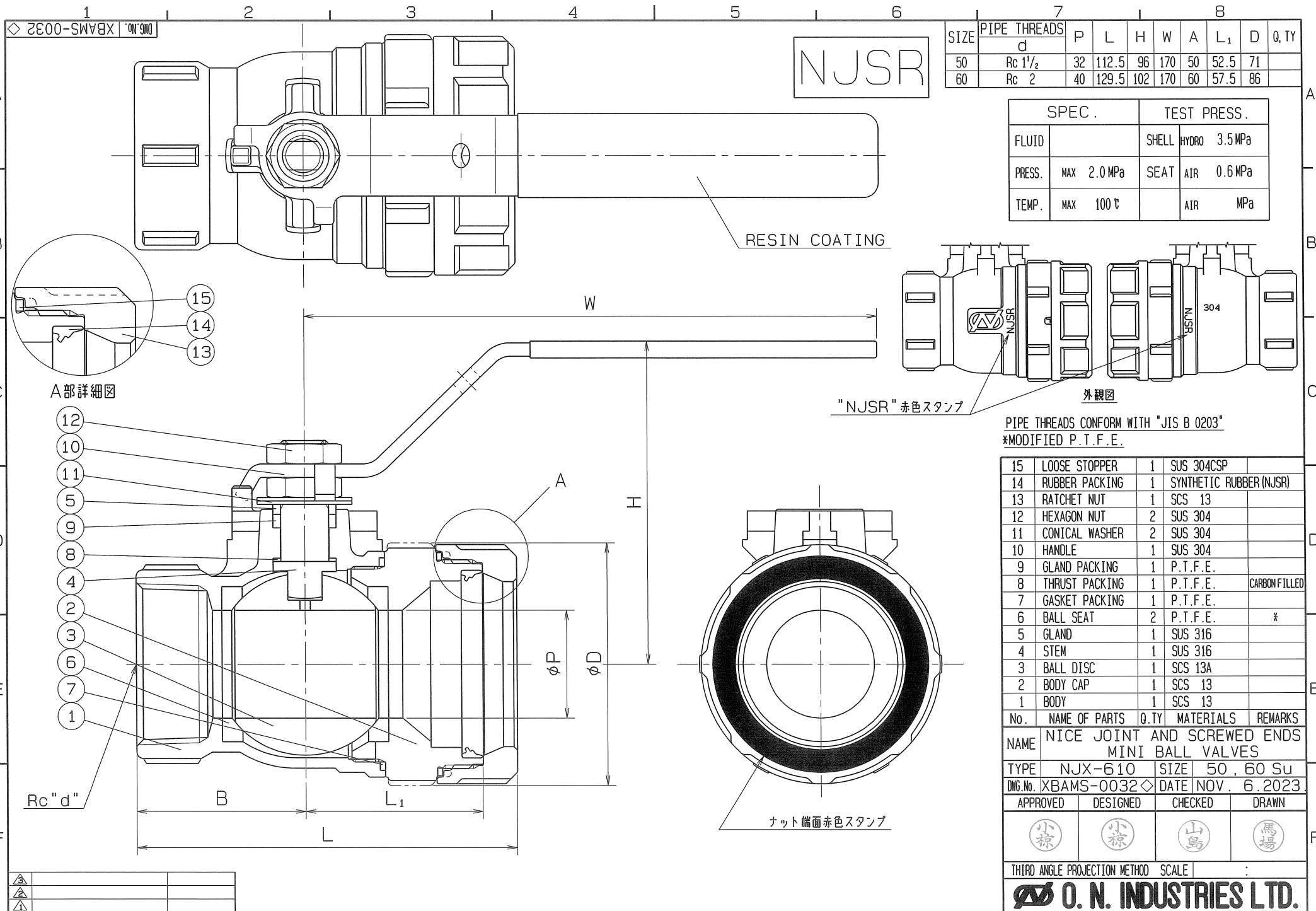

◇ 2E00-SWBX XBAMS-0032

NJSR

SIZE	PIPE THREADS	P	L	H	W	A	L ₁	D	Q, TY
	d								
50	Rc 1 1/2	32	112.5	96	170	50	52.5	71	
60	Rc 2	40	129.5	102	170	60	57.5	86	

SPEC.		TEST PRESS.	
FLUID		SHELL	HYDRO 3.5 MPa
PRESS.	MAX 2.0 MPa	SEAT	AIR 0.6 MPa
TEMP.	MAX 100 °C		AIR MPa

PIPE THREADS CONFORM WITH "JIS B 0203"
*MODIFIED P.T.F.E.

No.	NAME OF PARTS	Q.TY	MATERIALS	REMARKS
15	LOOSE STOPPER	1	SUS 304CSP	
14	RUBBER PACKING	1	SYNTHETIC RUBBER (NJSR)	
13	RATCHET NUT	1	SCS 13	
12	HEXAGON NUT	2	SUS 304	
11	CONICAL WASHER	2	SUS 304	
10	HANDLE	1	SUS 304	
9	GLAND PACKING	1	P.T.F.E.	
8	THRUST PACKING	1	P.T.F.E.	CARBON FILLED
7	GASKET PACKING	1	P.T.F.E.	
6	BALL SEAT	2	P.T.F.E.	*
5	GLAND	1	SUS 316	
4	STEM	1	SUS 316	
3	BALL DISC	1	SCS 13A	
2	BODY CAP	1	SCS 13	
1	BODY	1	SCS 13	

NAME NICE JOINT AND SCREWED ENDS
MINI BALL VALVES

TYPE NJX-610 SIZE 50, 60 Su

DRG.No. XBAMS-0032 DATE NOV. 6. 2023

APPROVED DESIGNED CHECKED DRAWN

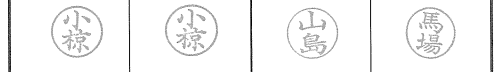

THIRD ANGLE PROJECTION METHOD SCALE :

O. N. INDUSTRIES LTD.