

SIZE	P	L	PIPE THREADS		H	W	D	S	F	K	J	M	CYLINDER SIZE	Q, TY
			d											
2	50	142	Rc	2	272	241	98	68	56.5	49.5	G1/8	65	AT251US08	
2·1/2	65	165	Rc	2·1/2	294	259	119	85	63	55.5	G1/4	76	AT301US08	
3	80	190	Rc	3	356	333	146	99	77	69.5	G1/4	93	AT401US08	

SPEC.		TEST PRESS.	
FLUID	清水	SHELL	HYDRO 2.1 MPa (21.4kgf/cm ²)
PRESS.	0.98 MPa (10 kgf/cm ²) 以下	SEAT	AIR 0.6 MPa (6.1kgf/cm ²)
TEMP.	常温	AIR	MPa (kgf/cm ²)

注) 上記の流体条件と異なる場合
シリンダサイズが変更になる場合があります。

TORQUE CYLINDER

TYPE	ATUS08		
ACTION	SINGLE	OPERATION PROPERTY	ON-OFF
SUPPLY PRESSURE	0.39 MPa (4 kgf/cm ²)	HAND DEVICE	NOTHING

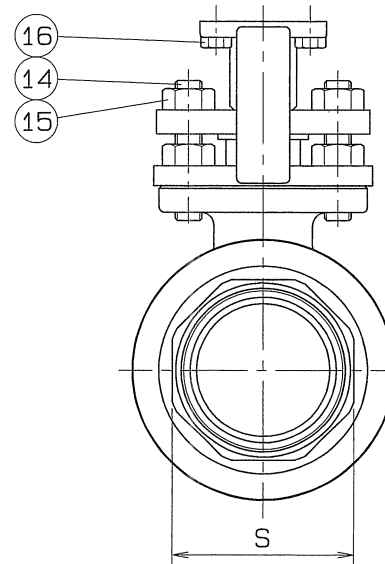

OPERATION

PORT2 AIR SUPPLY : LEFT TURN - VALVE OPEN
PORT2 AIR FAILURE : RIGHT TURN - VALVE SHUT

PIPE THREADS CONFORM WITH 'JIS B 0203' TAPER

No.	NAME OF PARTS	Q.TY	MATERIALS	REMARKS
19	CAP HEAD BOLT	1	SUS 304	
18	INDICATOR	1	SCS 13	
17	TORQUE CYLINDER	1		
16	HEXAGON BOLT	4	SUS 304	
15	HEXAGON NUT	4	SUS 304	
14	GLAND BOLT	2	SUS 304	
13	COUPLING	1	SCS 13	
12	BRACKET	1	SCS 13	
11	STEM BEARING	1	P.T.F.E.	GLASS FILLED
10	THRUST BEARING	1	P.T.F.E.	GLASS FILLED
9	GLAND PACKING	1	P.T.F.E.	
8	GASKET PACKING	1	P.T.F.E.	
7	BALL SEAT	2	P.T.F.E.	
6	STEM	1	SUS 316	
5	GLAND SLEEVE	1	SUS 316	
4	GLAND	1	SCS 13	
3	BALL DISC	1	SCS 14A	
2	BODY CAP	1	SCS 14A	
1	BODY	1	SCS 14A	

No.	NAME OF PARTS	Q.TY	MATERIALS	REMARKS
NAME JIS10K SCREWED ENDS (SINGLE ACTION) CYLINDER OPERATED MINI BALL VALVES				
TYPE	N-620HYS2	SIZE	2~3B	
DWG.No.	BAAS-5191	APPROVED BY	S. Yumoto	
DATE	APR. 7.2011	CHECKED BY	S. Yumoto	
SCALE		DESIGNED BY		

THIRD ANGLE PROJECTION METHOD DRAWN BY H. Miura

O. N. INDUSTRIES LTD.