

SIZE	P	L	PIPE THREADS	D	S	H	Q, TY
			d				
1-1/4	32	107	Rc 1-1/4	67	50	206	
1-1/2	40	117	Rc 1-1/2	80	57	212	

SPEC.		TEST PRESS.	
FLUID	清水	SHELL	HYDRO 2.1 MPa (21.4kgf/cm ²)
PRESS.	0.98 MPa (10 kgf/cm ²) 以下	SEAT	AIR 0.6 MPa (6.1kgf/cm ²)
TEMP.	常温	AIR	MPa (kgf/cm ²)

注) 上記の流体条件と異なる場合
シリンダサイズが変更になる場合
があります。

TORQUE CYLINDER

TYPE	AT201US0B		
ACTION	SINGLE	OPERATION PROPERTY	ON-OFF
SUPPLY PRESSURE	0.39 MPa (4 kgf/cm ²)	HAND DEVICE	NOTHING

OPERATION

PORT2 AIR SUPPLY : LEFT TURN - VALVE OPEN
PORT2 AIR FAILURE : RIGHT TURN - VALVE SHUT

PIPE THREADS CONFORM WITH 'JIS B 0203' TAPER

No.	NAME OF PARTS	Q. TY	MATERIALS	REMARKS
18	CAP HEAD BOLT	1	SUS 304	
17	INDICATOR	1	SCS 13	
16	COUPLING	1	SCS 13	
15	TORQUE CYLINDER	1		
14	HEXAGON BOLT	4	SUS 304	
13	SET BOLT	4	SUS 304	
12	BRACKET	1	SCS 13	
11	HEXAGON NUT	1	SUS 304	
10	SPRING WASHER	2	SUS 304	
9	GLAND PACKING	1	P.T.F.E.	
8	THRUST PACKING	1	P.T.F.E.	CARBON FILLED
7	GASKET PACKING	1	P.T.F.E.	
6	BALL SEAT	2	P.T.F.E.	
5	GLAND	1	SUS 316	
4	STEM	1	SUS 316	
3	BALL DISC	1	SCS 14A	
2	BODY CAP	1	SCS 14	
1	BODY	1	SCS 14	

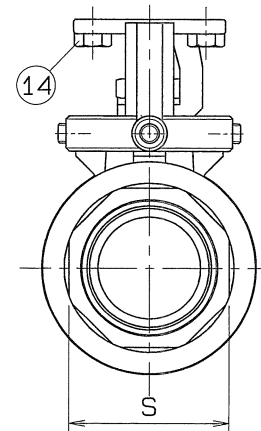
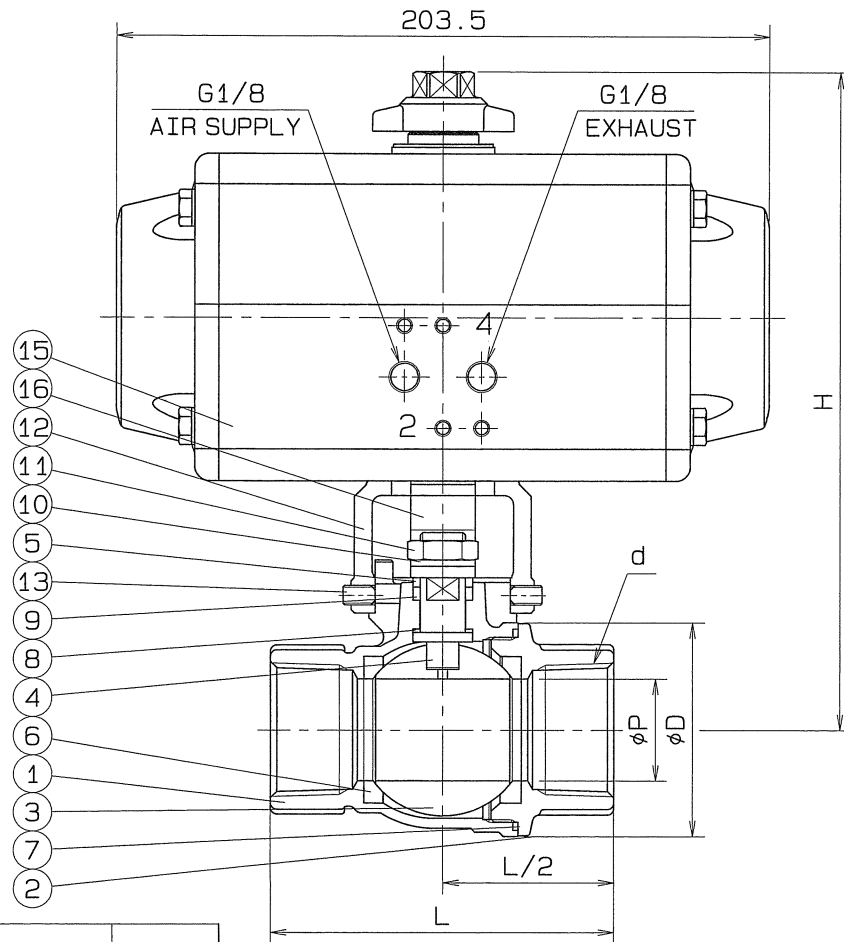

No.	NAME OF PARTS	Q. TY	MATERIALS	REMARKS
NAME	JIS10K SCREWED ENDS (SINGLE ACTION) CYLINDER OPERATED MINI BALL VALVES			
TYPE	N-620HYS2	SIZE	1-1/4, 1-1/2B	
DWG. No.	BAAS-5190	APPROVED BY	S. Yamato	
DATE	APR. 7. 2011	CHECKED BY	H. Asakura	
SCALE		DESIGNED BY		
THIRD ANGLE PROJECTION METHOD		DRAWN BY	H. Miura	

O. N. INDUSTRIES LTD.