

◇ DWG. NO. BAAS-5164

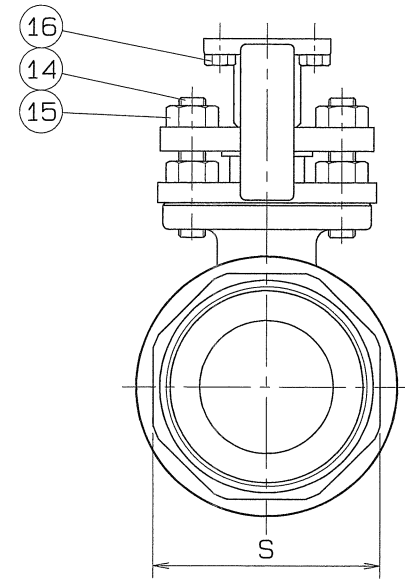
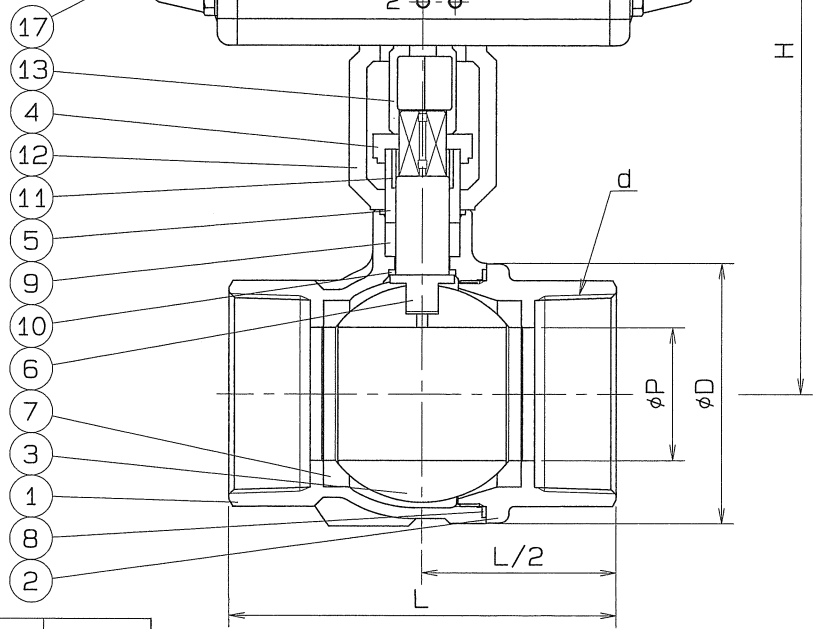
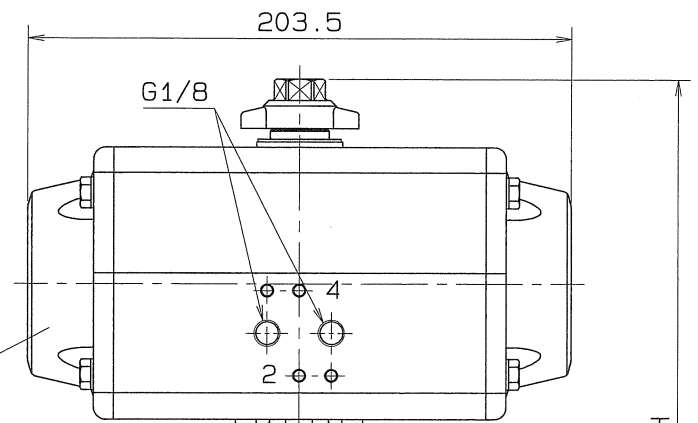
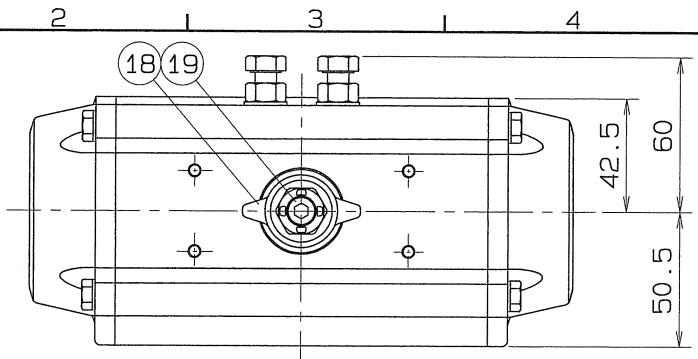

SIZE	P	L	PIPE THREADS		H	D	S	Q, TY
			d					
2-1/2	50	145	Rc 2-1/2		257	98	85	
3	65	170	Rc 3		267	119	99	

SPEC.		TEST PRESS.	
FLUID	清水	SHELL	HYDRO 2.1 MPa (21.4kgf/cm ²)
PRESS.	0.98 MPa (10 kgf/cm ²) 以下	SEAT	AIR 0.6 MPa (6.1kgf/cm ²)
TEMP.	常温		AIR (MPa kgf/cm ²)

注) 上記の流体条件と異なる場合
シリンダサイズが変更になる場合があります。

TORQUE CYLINDER			
TYPE	AT201UD		
ACTION	DOUBLE	OPERATION PROPERTY	ON-OFF
SUPPLY PRESSURE	0.39 MPa (4 kgf/cm ²)	HAND DEVICE	NOTHING

OPERATION
PORT2 AIR SUPPLY : LEFT TURN - VALVE OPEN
PORT4 AIR SUPPLY : RIGHT TURN - VALVE SHUT

PIPE THREADS CONFORM WITH 'JIS B 0203' TAPER

No.	NAME OF PARTS	Q.TY	MATERIALS	REMARKS
19	CAP HEAD BOLT	1	SUS 304	
18	INDICATOR	1	SCS 13	
17	TORQUE CYLINDER	1		
16	HEXAGON BOLT	4	SUS 304	
15	HEXAGON NUT	4	SUS 304	
14	GLAND BOLT	2	SUS 304	
13	COUPLING	1	SCS 13	
12	BRACKET	1	SCS 13	
11	STEM BEARING	1	P.T.F.E.	GLASS FILLED
10	THRUST BEARING	1	P.T.F.E.	GLASS FILLED
9	GLAND PACKING	1	P.T.F.E.	
8	GASKET PACKING	1	P.T.F.E.	
7	BALL SEAT	2	P.T.F.E.	
6	STEM	1	SUS 316	
5	GLAND SLEEVE	1	SUS 316	
4	GLAND	1	SCS 13	
3	BALL DISC	1	SCS 14A	
2	BODY CAP	1	SCS 14A	
1	BODY	1	SCS 14A	

NAME	JIS10K SCREWED ENDS (DOUBLE ACTION) CYLINDER OPERATED MINI BALL VALVES
TYPE	N-610HY2
SIZE	2-1/2, 3B
DWG.No.	BAAS-5164 ◇
DATE	FEB. 21, 2011
SCALE	
THIRD ANGLE PROJECTION METHOD	

APPROVED BY *K Yamato*
CHECKED BY *H. Miura*
DESIGNED BY
DRAWN BY *H. Miura*

O. N. INDUSTRIES LTD.