

SIZE	P	L	PIPE THREADS	A	B	H	W	F	K	M	CYLINDER SIZE	Q, TY
			d									
1	20	100	Rc 1	49.5	27	187	135.5	42	29	43	AT051UD	
1 1/4	25	115	Rc 1 1/4	57	33.5	207	153.5	48.5	36	50	AT101UD	A
1 1/2	32	125	Rc 1 1/2	65	40	246	203.5	50.5	42.5	60	AT201UD	
2	40	150	Rc 2	76	44	252	203.5	50.5	42.5	60	AT201UD	

SPEC.		TEST PRESSURE	
FLUID	清水	SHELL	HYDRO 2.1 MPa (21.4kgf/cm ²)
PRESS.	0.98 MPa (10 kgf/cm ²) 以下	SEAT	AIR 0.6 MPa (6.1kgf/cm ²)
TEMP.	常温	AIR	MPa (kgf/cm ²)

注) 上記の流体条件と異なる場合
シリンダサイズが変更になる場合があります。

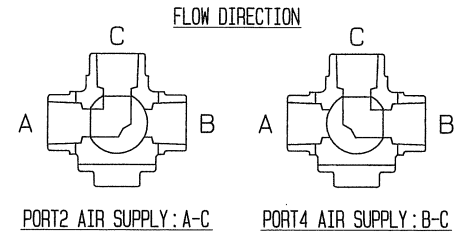

TORQUE CYLINDER

TYPE	ATUD		
ACTION	DOUBLE	OPERATION PROPERTY	ON-OFF
SUPPLY PRESSURE	0.39 MPa (4 kgf/cm ²)	HAND DEVICE	NOTHING

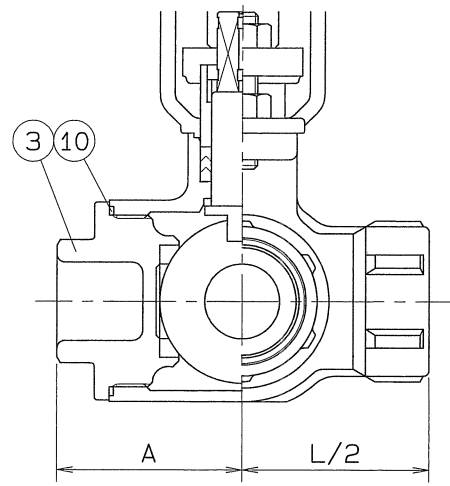

PIPE THREADS CONFORM WITH 'JIS B 0203'

21	CAP HEAD BOLT	1	SUS 304	
20	INDICATOR	1	SCS 13	
19	TORQUE CYLINDER	1		
18	HEXAGON BOLT	4	SUS 304	
17	COUPLING	1	SCS 13	
16	BRACKET	1	SCS 13	
15	HEXAGON NUT	4	SUS 304	
14	GLAND BOLT	2	SUS 304	
13	STEM BEARING	1	P.T.F.E.	GLASS FILLED
12	GLAND PACKING	1SET	P.T.F.E.	
11	THRUST BEARING	1	P.T.F.E.	GLASS FILLED
10	GASKET PACKING	1	P.T.F.E.	
9	GASKET PACKING	2	P.T.F.E.	
8	BALL SEAT	4	P.T.F.E.	
7	GLAND	1	SCS 13	
6	GLAND SLEEVE	1	SUS 316	
5	STEM	1	SUS 316	
4	BALL DISC	1	SUS 316	
3	BLIND CAP	1	SCS 14	
2	BODY CAP	2	SCS 14	
1	BODY	1	SCS 14	

No.	NAME OF PARTS	Q.TY	MATERIALS	REMARKS
NAME JIS 10K SCREWED ENDS TORQUE CYLINDER OPE. THREE WAY BALL VALVES				
TYPE	N-730L-HY2	SIZE	1~2B	
DMG.No.	BAAS-5137	APPROVED BY	K. Yamato	
DATE	FEB. 18. 2011	CHECKED BY	M. Hatakeyama	
SCALE		DESIGNED BY		
THIRD ANGLE PROJECTION METHOD		DRAWN BY	K. Shitao	