

DMG. No. BATS-0902

SIZE	P	L	PIPE THREADS	A	H	W	C	E	G	Q. TY
			d							
1/2	10	75	Rc 1/2	39	94	130	67	19	7	
3/4	15	85	Rc 3/4	43	98	130	71	23	7	

SPEC.		TEST PRESS.	
FLUID		SHELL	HYDRO 2.1 MPa (21.4 kgf/cm <sup>2</sup> )
PRESS.	MPa ( kgf/cm <sup>2</sup> )	SEAT	AIR 0.6 MPa (6.1 kgf/cm <sup>2</sup> )
TEMP.	°C	AIR	MPa ( kgf/cm <sup>2</sup> )

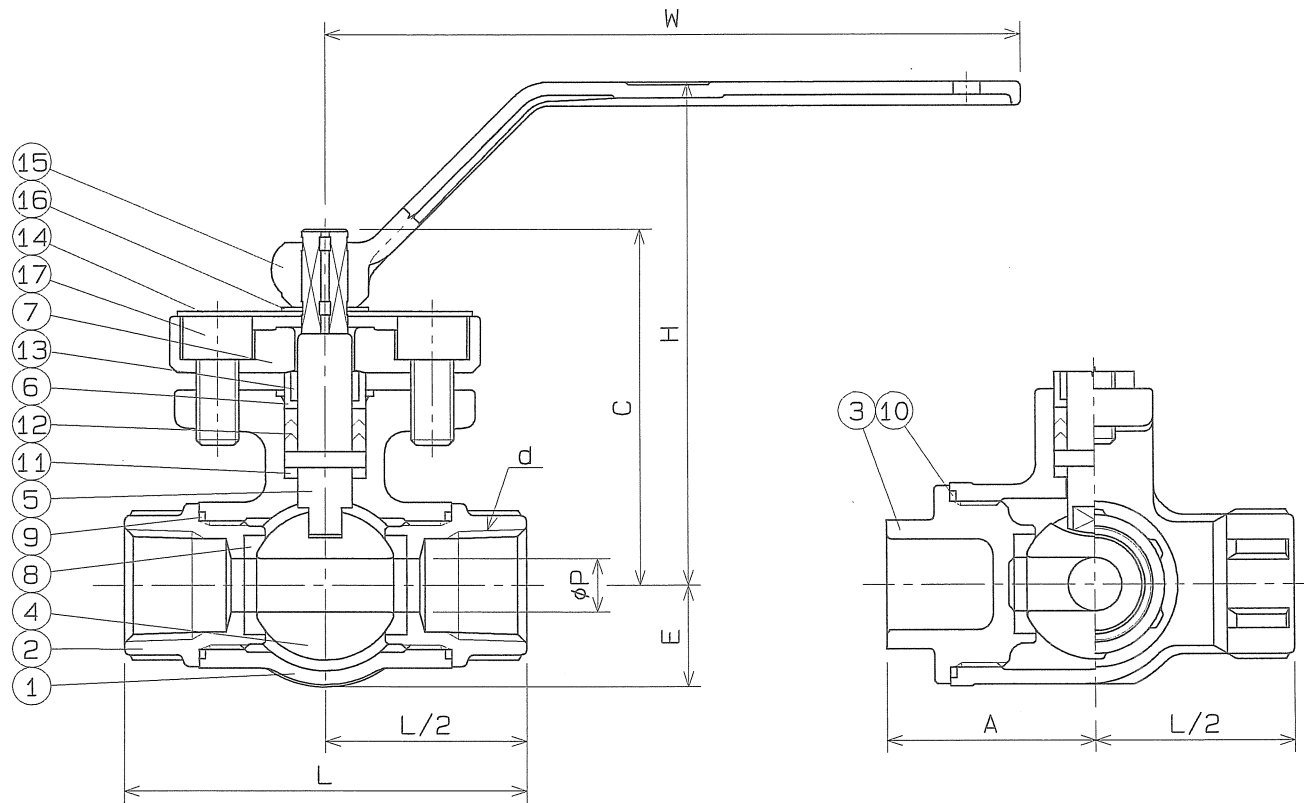
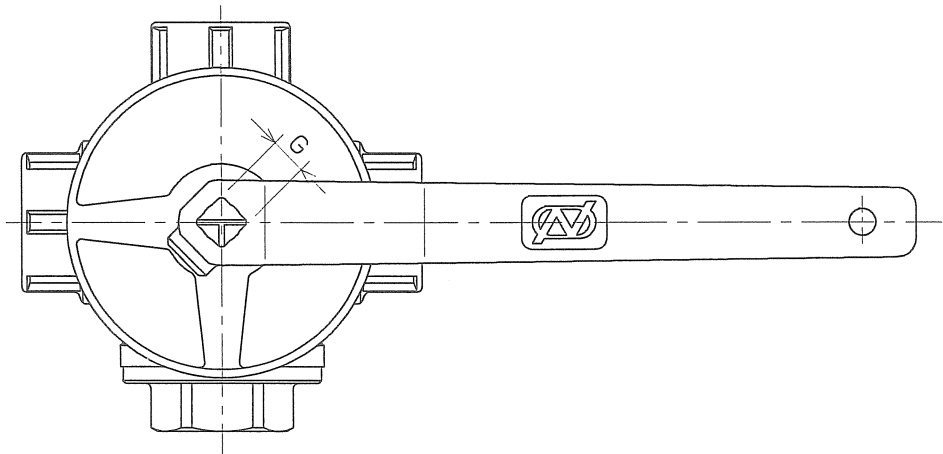

PIPE THREADS CONFORM WITH "JIS B 0203" TAPER THREADS

No.	NAME OF PARTS	Q. TY	MATERIALS	REMARKS
17	GLAND BOLT	2	SUS 304	
16	STOP RING	1	SUS 304	
15	HAND LEVER	1	SCS 13	
14	FLOW PLATE	1	A1050P	
13	STEM BEARING	1	P.T.F.E.	GLASS FILLED
12	GLAND PACKING	1 SET	P.T.F.E.	
11	THRUST BEARING	1	P.T.F.E.	GLASS FILLED
10	GASKET PACKING	1	P.T.F.E.	
9	GASKET PACKING	2	P.T.F.E.	
8	BALL SEAT	4	P.T.F.E.	
7	GLAND	1	SCS 13	
6	GLAND SLEEVE	1	SUS 316	
5	STEM	1	SUS 316	
4	BALL DISC	1	SUS 316	
3	BLIND CAP	1	SCS 14	
2	BODY CAP	2	SCS 14	
1	BODY	1	SCS 14	

NAME JIS 10K SCREWED ENDS THREE WAY BALL VALVES				
TYPE N-730T		SIZE 1/2, 3/4B		
DMG. No.	BATS-0902	APPROVED BY	<i>[Signature]</i>	
DATE	DEC. 2. 2004	CHECKED BY	<i>[Signature]</i>	
SCALE	:	DESIGNED BY	-	
THIRD ANGLE PROJECTION METHOD		DRAWN BY	<i>X. Takei</i>	

△ \*SCS14製の部品はロスト・ワックス鋳造法で製造しています

△		
△	注釈の追記	'06. 3. 13.

**O. N. INDUSTRIES LTD.**