

◇ OEG60-SMVB BAMS-0930

| SIZE  | PIPE THREADS | P  | L   | H   | W   | D  | Q, TY |
|-------|--------------|----|-----|-----|-----|----|-------|
|       | d            |    |     |     |     |    |       |
| 1 1/2 | Rc 1 1/2     | 32 | 100 | 96  | 170 | 67 |       |
| 2     | Rc 2         | 40 | 120 | 102 | 170 | 80 |       |

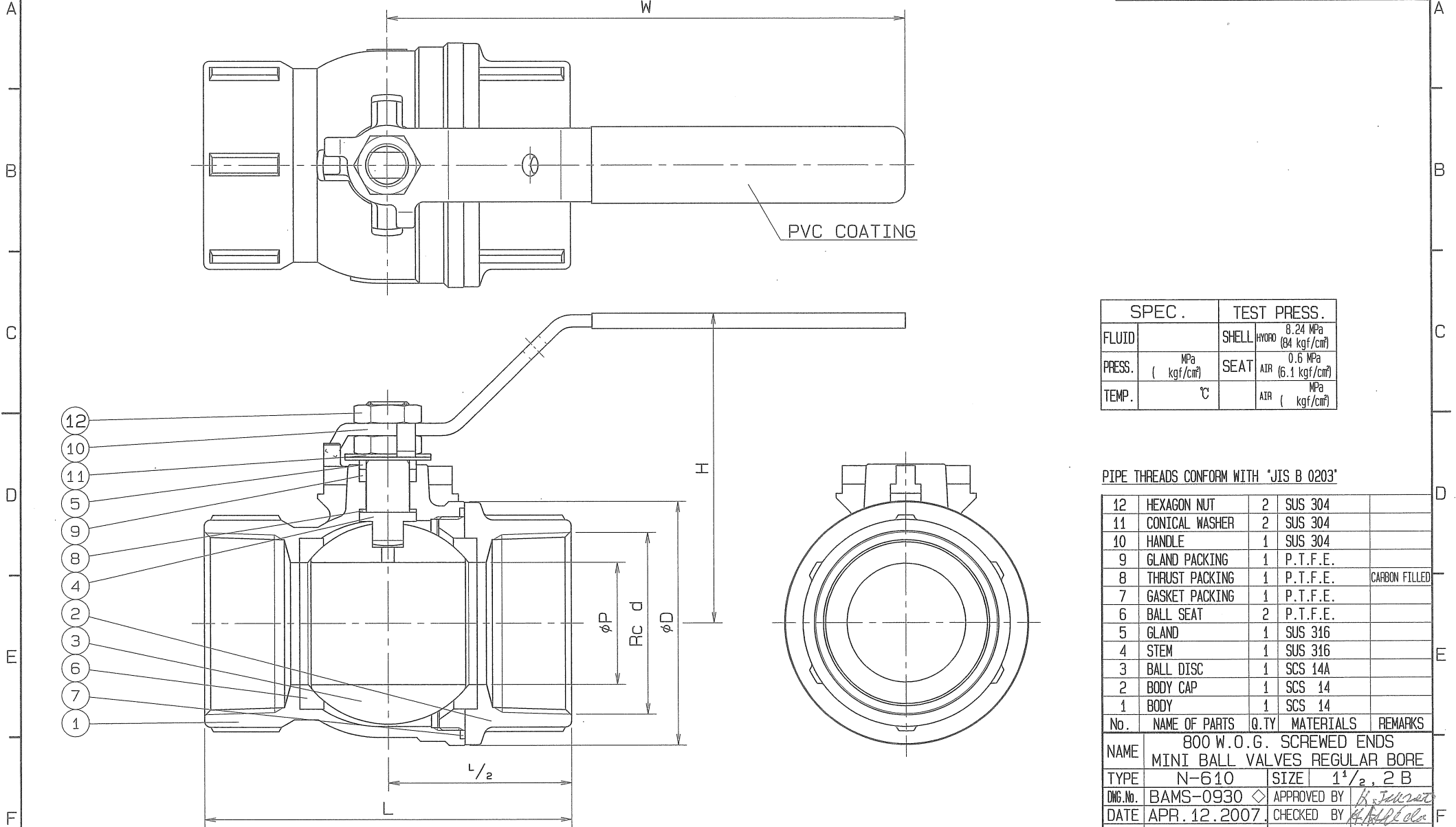

| SPEC.  |                             | TEST PRESS. |  |
|--------|-----------------------------|-------------|--|
| FLUID  |                             | SHELL       | HYDRO 8.24 MPa (84 kgf/cm <sup>2</sup> ) |
| PRESS. | MPa ( kgf/cm <sup>2</sup> ) | SEAT        | AIR 0.6 MPa (6.1 kgf/cm <sup>2</sup> )   |
| TEMP.  | °C                          | AIR         | MPa ( kgf/cm <sup>2</sup> )              |

PIPE THREADS CONFORM WITH "JIS B 0203"

| No. | NAME OF PARTS  | Q. TY | MATERIALS | REMARKS       |
|-----|----------------|-------|-----------|---------------|
| 12  | HEXAGON NUT    | 2     | SUS 304   |               |
| 11  | CONICAL WASHER | 2     | SUS 304   |               |
| 10  | HANDLE         | 1     | SUS 304   |               |
| 9   | GLAND PACKING  | 1     | P.T.F.E.  |               |
| 8   | THRUST PACKING | 1     | P.T.F.E.  | CARBON FILLED |
| 7   | GASKET PACKING | 1     | P.T.F.E.  |               |
| 6   | BALL SEAT      | 2     | P.T.F.E.  |               |
| 5   | GLAND          | 1     | SUS 316   |               |
| 4   | STEM           | 1     | SUS 316   |               |
| 3   | BALL DISC      | 1     | SCS 14A   |               |
| 2   | BODY CAP       | 1     | SCS 14    |               |
| 1   | BODY           | 1     | SCS 14    |               |

|                               |               |                             |                    |
|-------------------------------|---------------|-----------------------------|--------------------|
| NAME 800 W.O.G. SCREWED ENDS  |               |                             |                    |
| MINI BALL VALVES REGULAR BORE |               |                             |                    |
| TYPE                          | N-610         | SIZE                        | 1 1/2, 2 B         |
| DWG.No.                       | BAMS-0930 ◇   | APPROVED BY                 | <i>K. Taketani</i> |
| DATE                          | APR. 12. 2007 | CHECKED BY                  | <i>K. Taketani</i> |
| SCALE                         | :             | DESIGNED BY                 | -                  |
| THIRD ANGLE PROJECTION METHOD |               | DRAWN BY <i>N. Taketani</i> |                    |

**O. N. INDUSTRIES LTD.**

|   |  |  |
|---|--|--|
| △ |  |  |
| △ |  |  |
| △ |  |  |