

◇ Dwg.No. BAMS-0924

SIZE	PIPE THREADS		P	L	H	W	D	S	Q, TY
	d								
1 1/4	Rc 1 1/4		32	107	96	170	67	50	
1 1/2	Rc 1 1/2		40	117	102	170	80	57	

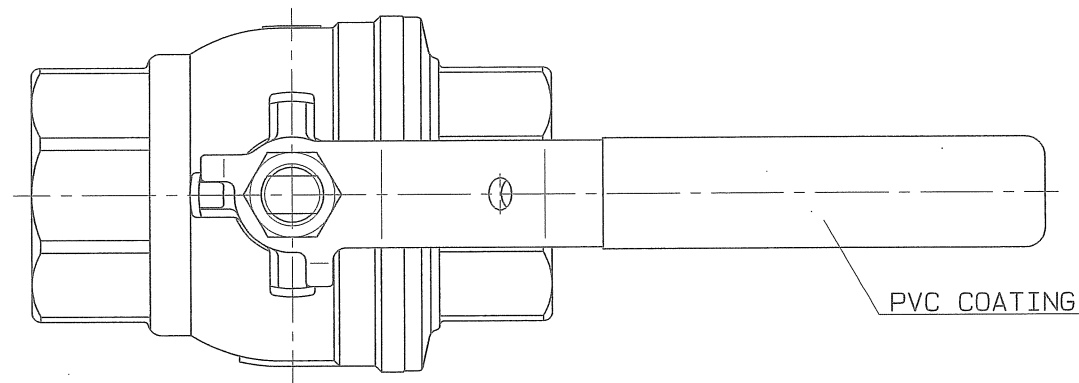

- 12
- 10
- 11
- 5
- 9
- 8
- 4
- 2
- 3
- 6
- 7
- 1

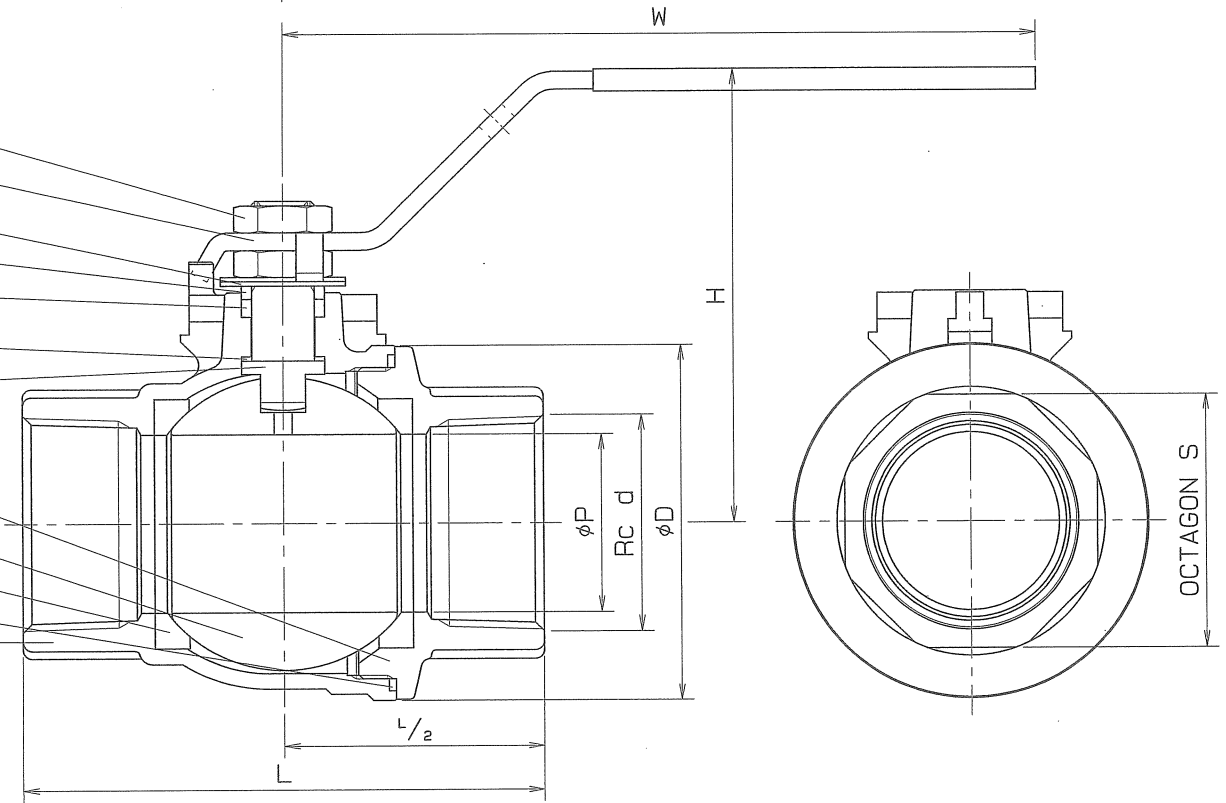

SPEC.		TEST PRESS.	
FLUID		SHELL	HYDRO 8.24 MPa (84 kgf/cm ²)
PRESS.	MPa (kgf/cm ²)	SEAT	AIR 0.6 MPa (6.1 kgf/cm ²)
TEMP.	°C	AIR	MPa (kgf/cm ²)

PIPE THREADS CONFORM WITH "JIS B 0203"

No.	NAME OF PARTS	Q.TY	MATERIALS	REMARKS
12	HEXAGON NUT	2	SUS 304	
11	CONICAL WASHER	2	SUS 304	
10	HANDLE	1	SUS 304	
9	GLAND PACKING	1	P.T.F.E.	
8	THRUST PACKING	1	P.T.F.E.	CARBON FILLED
7	GASKET PACKING	1	P.T.F.E.	
6	BALL SEAT	2	P.T.F.E.	
5	GLAND	1	SUS 316	
4	STEM	1	SUS 316	
3	BALL DISC	1	SCS 14A	
2	BODY CAP	1	SCS 14	
1	BODY	1	SCS 14	

NAME 800 W.O.G. SCREWED ENDS MINI BALL VALVES FULL BORE				
TYPE N-620		SIZE 1 1/4, 1 1/2 B		
DWG.No. BAMS-0924	APPROVED BY	<i>[Signature]</i>		
DATE APR. 12. 2007.	CHECKED BY	<i>[Signature]</i>		
SCALE :	DESIGNED BY	-		
THIRD ANGLE PROJECTION METHOD		DRAWN BY <i>[Signature]</i>		

O. N. INDUSTRIES LTD.