

◇ 96TG-SVVB 'ON' SMC

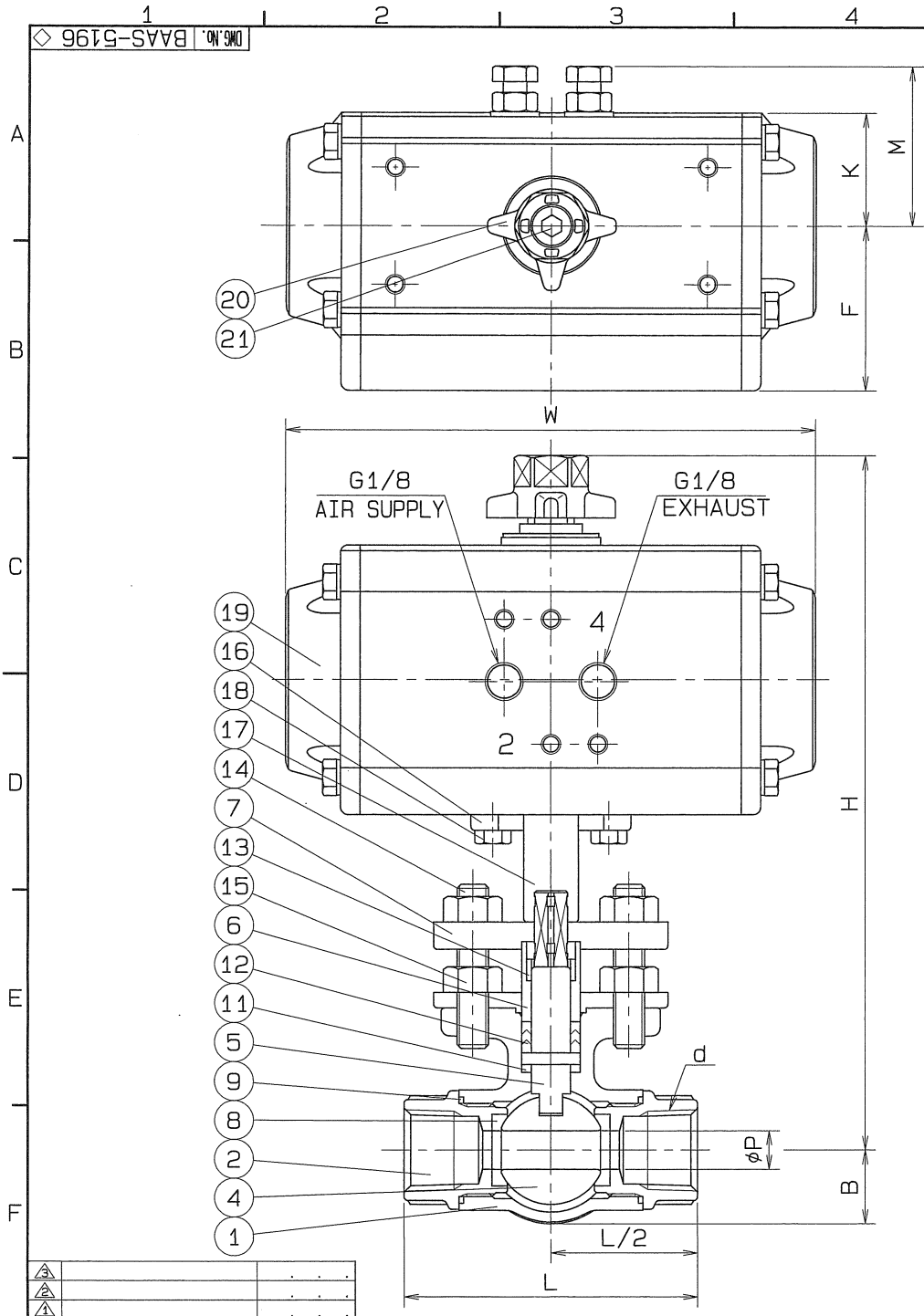

SIZE	P	L	PIPE THREADS		A	B	H	W	F	K	M	CYLINDER SIZE	Q, TY
			d										
1/2	10	75	Rc	1/2	39	19	179	135.5	42	29	43	AT051US4	
3/4	15	85	Rc	3/4	43	23	199	153.5	48.5	36	50	AT101US08	

SPEC.		TEST PRESSURE	
FLUID	清水	SHELL	HYDRO 2.1 MPa (21.4kgf/cm <sup>2</sup> )
PRESS.	0.98 MPa (10 kgf/cm <sup>2</sup> ) 以下	SEAT	AIR 0.6 MPa (6.1kgf/cm <sup>2</sup> )
TEMP.	常温	AIR	MPa ( kgf/cm <sup>2</sup> )

注) 上記の流体条件と異なる場合  
シリンダサイズが変更になる場合があります。

TORQUE CYLINDER

TYPE	ATUS		
ACTION	SINGLE	OPERATION PROPERTY	ON-OFF
SUPPLY PRESSURE	0.39 MPa (4 kgf/cm <sup>2</sup> )	HAND DEVICE	NOTHING

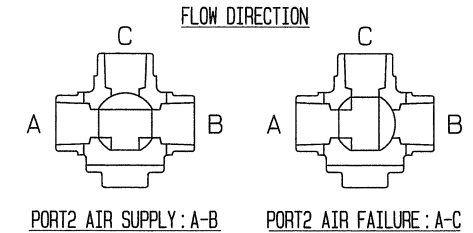

PIPE THREADS CONFORM WITH 'JIS B 0203'

No.	NAME OF PARTS	Q. TY	MATERIALS	REMARKS
21	CAP HEAD BOLT	1	SUS 304	
20	INDICATOR	1	SCS 13	
19	TORQUE CYLINDER	1		
18	HEXAGON BOLT	4	SUS 304	
17	COUPLING	1	SCS 13	
16	BRACKET	1	SCS 13	
15	HEXAGON NUT	4	SUS 304	
14	GLAND BOLT	2	SUS 304	
13	STEM BEARING	1	P.T.F.E.	GLASS FILLED
12	GLAND PACKING	1set	P.T.F.E.	
11	THRUST BEARING	1	P.T.F.E.	GLASS FILLED
10	GASKET PACKING	1	P.T.F.E.	
9	GASKET PACKING	2	P.T.F.E.	
8	BALL SEAT	4	P.T.F.E.	
7	GLAND	1	SCS 13	
6	GLAND SLEEVE	1	SUS 316	
5	STEM	1	SUS 304	
4	BALL DISC	1	SUS 304	
3	BLIND CAP	1	SCS 13	
2	BODY CAP	2	SCS 13	
1	BODY	1	SCS 13	

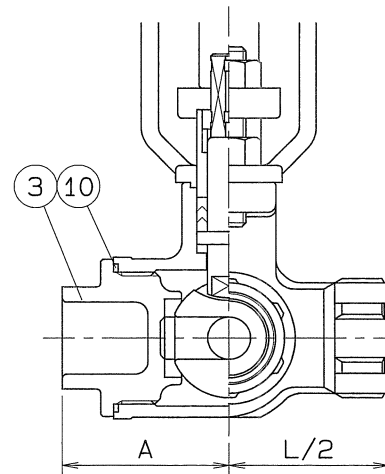

NAME	JIS 10K SCREWED ENDS TORQUE CYLINDER OPE. THREE WAY BALL VALVES		
TYPE	N-730T-HYS2	SIZE	1/2, 3/4B
DMG.No.	BAAS-5196 ◇	APPROVED BY	K. Jumeita
DATE	APR. 7.2011	CHECKED BY	H. Asakida
SCALE	:	DESIGNED BY	
THIRD ANGLE PROJECTION METHOD	DRAWN BY H. Miura		

**O. N. INDUSTRIES LTD.**