

◇ 619-SVVB 'ON' SMC
DWG.No. BAAS-5193

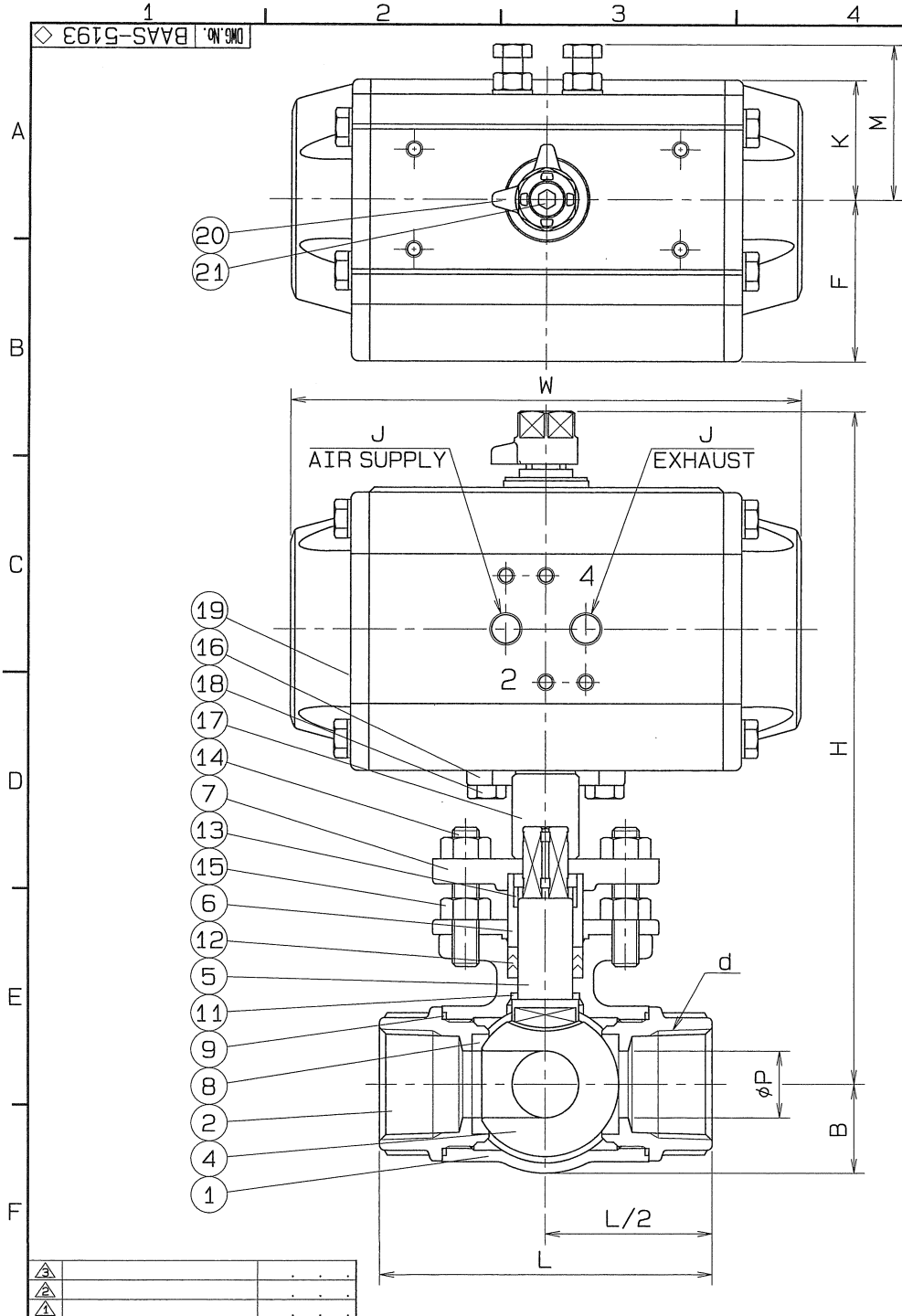

SIZE	P	L	PIPE THREADS		A	B	H	W	F	K	J	M	CYLINDER SIZE	Q, TY
			d											
1	20	100	Rc	1	49.5	27	204	153.5	48.5	36	G1/8	50	AT101US08	
1 1/4	25	115	Rc	1 1/4	57	33.5	224	203.5	50.5	42.5	G1/8	60	AT201US08	
1 1/2	32	125	Rc	1 1/2	65	40	260	241	56.5	49.5	G1/8	65	AT251US08	
2	40	150	Rc	2	76	44	279	259	63	55.5	G1/4	76	AT301US08	

SPEC.		TEST PRESSURE	
FLUID	清水	SHELL	HYDRO 2.1 MPa (21.4kgf/cm ²)
PRESS.	0.98 MPa (10 kgf/cm ²) 以下	SEAT	AIR 0.6 MPa (6.1kgf/cm ²)
TEMP.	常温	AIR	(kgf/cm ²) MPa

注) 上記の流体条件と異なる場合
シリンダサイズが変更になる場合があります。

TORQUE CYLINDER

TYPE	ATUS08		
ACTION	SINGLE	OPERATION PROPERTY	ON-OFF
SUPPLY PRESSURE	0.39 MPa (4 kgf/cm ²)	HAND DEVICE	NOTHING

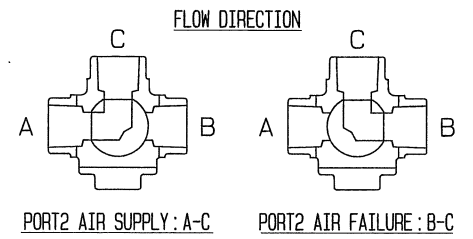

PIPE THREADS CONFORM WITH 'JIS B 0203'

21	CAP HEAD BOLT	1	SUS 304	
20	INDICATOR	1	SCS 13	
19	TORQUE CYLINDER	1		
18	HEXAGON BOLT	4	SUS 304	
17	COUPLING	1	SCS 13	
16	BRACKET	1	SCS 13	
15	HEXAGON NUT	4	SUS 304	
14	GLAND BOLT	2	SUS 304	
13	STEM BEARING	1	P.T.F.E.	GLASS FILLED
12	GLAND PACKING	1set	P.T.F.E.	
11	THRUST BEARING	1	P.T.F.E.	GLASS FILLED
10	GASKET PACKING	1	P.T.F.E.	
9	GASKET PACKING	2	P.T.F.E.	
8	BALL SEAT	4	P.T.F.E.	
7	GLAND	1	SCS 13	
6	GLAND SLEEVE	1	SUS 316	
5	STEM	1	SUS 304	
4	BALL DISC	1	SUS 304	
3	BLIND CAP	1	SCS 13	
2	BODY CAP	2	SCS 13	
1	BODY	1	SCS 13	

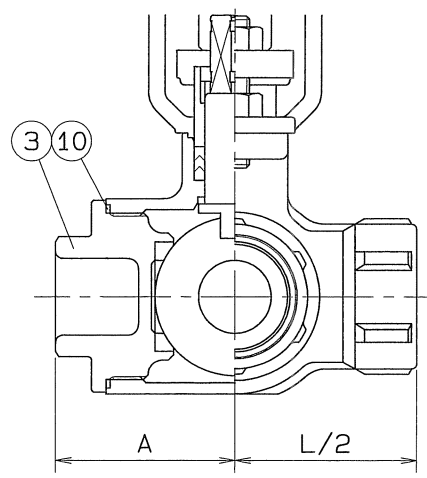

No.	NAME OF PARTS	Q. TY	MATERIALS	REMARKS
NAME	JIS 10K SCREWED ENDS TORQUE CYLINDER OPE. THREE WAY BALL VALVES			
TYPE	N-730L-HYS2	SIZE	1~2B	
DWG.No.	BAAS-5193	APPROVED BY	<i>K. Sumoto</i>	
DATE	APR. 7.2011	CHECKED BY	<i>A. Asai</i>	
SCALE	:	DESIGNED BY		
THIRD ANGLE PROJECTION METHOD		DRAWN BY	<i>H. Miura</i>	

O. N. INDUSTRIES LTD.