

◇ Dwg. No. BAAS-5157

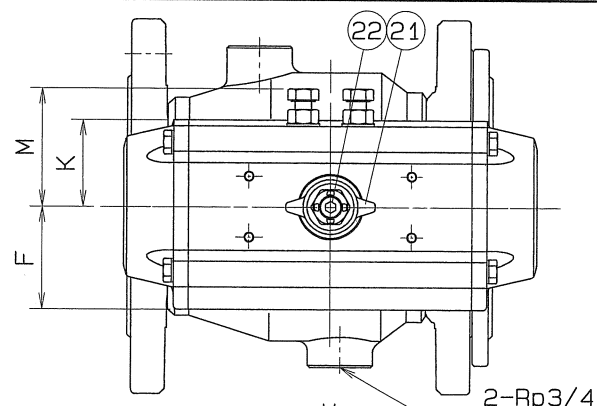

SIZE	d	d ₁	L	L ₁	D	T	T ₁	G	f	BOLT HOLE			A	B	B ₁	E	FLANGE SIZE	H	W	F	K	M	J	CYLINDER SIZE	Q. TY
										C	n	h													
15	15	-	110	59.5	140	16	25.5	81	2	105	4	19	50.5	50.5	59.5	1/2	40	214	135.5	42	29	43	61/8	AT051UD	
20	20	-	120	64.5	140	16	25.5	81	2	105	4	19	55.5	55.5	64.5	1/2	40	218	135.5	42	29	43	61/8	AT051UD	
25	25	-	130	69.5	155	16	25.5	96	2	120	4	19	60.5	60.5	69.5	1/2	50	221	135.5	42	29	43	61/8	AT051UD	
40	40	-	165	82.5	175	18	27.5	116	2	140	4	19	90	65	75	3/4	65	279	203.5	50.5	42.5	60	61/8	AT201UD	
50	50	-	180	90	185	18	27.5	126	2	150	4	19	100	65	75	3/4	80	301	203.5	50.5	42.5	60	61/8	AT201UD	
65	65	-	190	95	210	18	30.5	151	2	175	8	19	102	65	78	3/4	100	321	241	56.5	49.5	65	61/8	AT251UD	
80	65	80	200	100	210	18	30.5	151	2	175	8	19	112	65	78	3/4	100	321	241	56.5	49.5	65	61/8	AT251UD	
100	80	100	230	115	280	22	37.5	212	2	240	8	23	128	65	81	3/4	150	389	259	63	55.5	76	61/4	AT301UD	

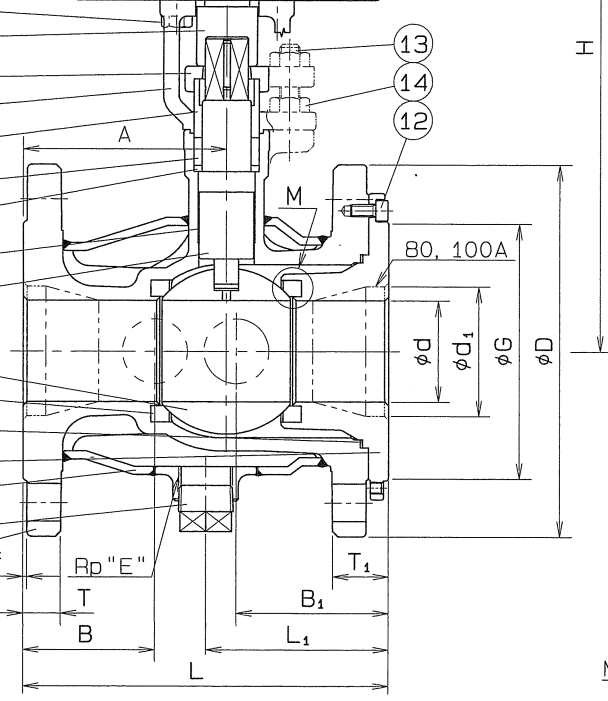
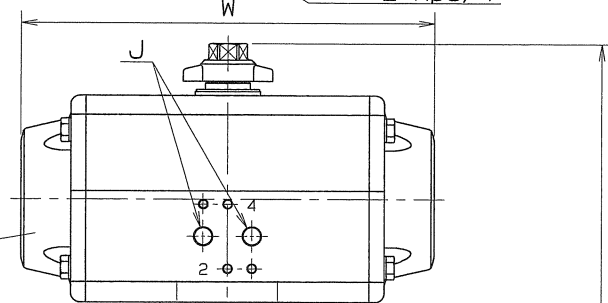

SPEC.		TEST PRESSURE	
FLUID	清水	SHELL	HYDRO 2.1 MPa (21.4kgf/cm ²)
PRESS.	0.98 MPa (10 kgf/cm ²) 以下	SEAT	AIR 0.6 MPa (6.1kgf/cm ²)
TEMP.	常温	JACKET	AIR 0.6 MPa (6.1kgf/cm ²)

注) 上記の流体条件と異なる場合
シリンダサイズが変更になる場合があります。

OPERATION
PORT2 AIR SUPPLY : LEFT TURN - VALVE OPEN
PORT4 AIR SUPPLY : RIGHT TURN - VALVE SHUT

END FLANGED : JIS B 2220

TORQUE CYLINDER			
TYPE	ATUD		
ACTION	DOUBLE	OPERATION PROPERTY	ON-OFF
SUPPLY PRESSURE	0.39 MPa (4 kgf/cm ²)	HAND DEVICE	NOTHING

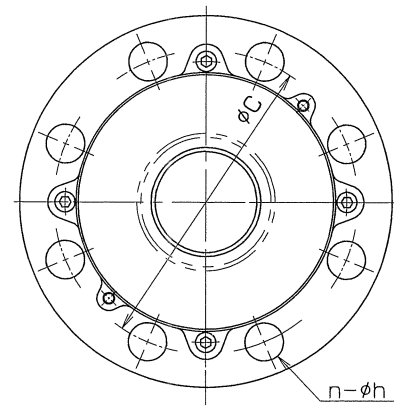

22	CAP HEAD BOLT	1	SUS 304	
21	INDICATOR	1	SCS 13	
20	TORQUE CYLINDER	1		
19	HEXAGON BOLT	4	SUS 304	
18	COUPLING	1	SCS 13	
17	BRACKET	1	SCS 13	
16	JACKET		SCS 13A	
15	DRAIN PLUG	1	SCS 13	R"E"
14	HEXAGON NUT	4	SUS 304	
13	GLAND BOLT	2	SUS 304	
12	SOCKET BOLT	4	SUS 304	
11	BEARING	1	P. T. F. E.	+SUS 316
10	GLAND PACKING	1SET	P. T. F. E.	CARBON FILLED
9	GASKET PACKING	1	P. T. F. E.	CARBON FILLED
8	BALL SEAT	2	P. T. F. E.	GLASS FILLED
7	THRUST RING	1	SUS 329J1	
6	GLAND	1	SCS 13	
5	GLAND SLEEVE	1	SUS 316	
4	STEM	1	SUS 304	
3	BALL DISC	1	SCS 13A	
2	SEAT HOLDER	1	SCS 13A	
1	BODY	1	SCS 13A	

No.	NAME OF PARTS	Q. TY	MATERIALS	REMARKS
NAME	JIS 10K R.F. FLANGED ENDS TORQUE CYLINDER OPE. JACKET TYPE STRAIGHT WAY BALL VALVES			
TYPE	N-7017HY2	SIZE	15~100A	
Dwg.No.	BAAS-5157	APPROVED BY	K. Ito	
DATE	FEB. 21, 2011.	CHECKED BY	H. Ando	
SCALE		DESIGNED BY		
THIRD ANGLE PROJECTION METHOD		DRAWN BY	K. Takahara	

